

---

## TABLE OF CONTENTS

### Chapter 1 – MOBILE EQUIPMENT POLICY AND PROCEDURE

Purpose.....	1
Authority.....	1
Scope.....	1
References.....	1
Training.....	1
Forms.....	1
Abbreviations.....	2
1.1. General Responsibilities	
1.1.1. Office of Maintenance.....	3
1.1.2. District Maintenance Engineer/Administrator.....	3
1.1.3. Maintenance Engineer/Operations Engineer/Manager.....	5
1.1.4. Mobile equipment Operators.....	6
1.2. Assignment of Vehicles	
1.2.1. Standard Passenger Carrying Vehicles.....	6
1.2.2. Vehicle Standardization.....	6
1.2.3. Vehicle Assignment Policy.....	9
1.2.3.1. General.....	9
1.2.3.2. Pool Vehicle Assignment (DMS Class A).....	11
1.2.3.3. Limited Use Assignment (DMS Class B).....	11
1.2.3.4. Special Asgmt. Veh. - Law Enforcement (DMS Class C).....	12
1.2.3.5. Special Asgmt. Veh. - Emergency Services (DMS Class E).....	12
1.2.3.6. Perquisite Vehicles (DMS Class C).....	13
1.2.4. License, Operation and Record Requirements.....	13
1.3. Replacement or Additional Mobile Equipment	
1.3.1. Funding.....	14
1.3.2. Mobile Equipment Replacement and Addition Process.....	14
1.3.2.1. General.....	14
1.3.2.2. Methods for Securing Replacement of Addit'l Mobile Equip.....	15
1.3.2.3. DMS Contracts.....	15

---

1.3.2.4.	FDOT Contracts.....	15
1.3.2.5.	Non-Contract Purchases or Rentals.....	15
1.3.2.6.	Short Term Rental Contracts.....	16
1.3.3.	Standard Specifications.....	16
1.3.4.	Approved Replacement List.....	16
1.3.5.	Procurement Requisition.....	17
1.3.5.1.	Initiate a Procurement Requisition.....	17
1.3.5.2.	Procurement Requisition Approvals.....	17
1.3.6.	Securing Non-Contract Purchases.....	17
1.4.	Mobile equipment Identification	
1.4.1.	Color.....	18
1.4.2.	Conspicuity Marking.....	18
1.4.3.	Description of Logos.....	19
1.4.4.	Numerals.....	19
1.4.5.	Location of Marking.....	19
1.4.6.	Vehicle Lighting.....	21
1.4.7.	License Plates and DOT Numbers.....	22
1.5.	Mobile equipment Utilization	
1.5.1.	General.....	22
1.5.2.	Identification of Under-Utilized Mobile Equipment.....	23
1.5.3.	Utilization Review Process.....	25
1.5.3.1.	Target List.....	25
1.5.4.	Self Service Motor Pool System.....	26
1.5.4.1.	General.....	26
1.5.4.2.	Grab and Go Local Vehicles at the Kiosk.....	26
1.5.4.3.	Make a Reservation Online.....	27
1.5.4.4.	Check Out a Reserved Vehicle.....	27
1.5.4.5.	Check in a Vehicle.....	28
1.6.	Maintenance	
1.6.1.	General.....	28
1.6.2.	Maintenance Categories.....	29
1.6.3.	Repair and Modification.....	30
1.6.4.	Trailer Towing Guidelines.....	30
1.7.	Fuel	
1.7.1.	General.....	36
1.7.2.	Fuel and Maintenance Card.....	36
1.7.3.	FDOT Fueling Facilities.....	36
1.7.3.1	Guidelines for Fuel Facilities Card Reader Equipment.....	36

---

1.7.3.2	Store and Forward.....	36
1.7.3.3	Fuel and Maintenance Card Assigned to District Shops.....	37
1.7.3.4	Remote Pump Activation.....	37
1.7.3.5	Keypad Access.....	37
1.7.4	Maintenance of Fueling Facilities.....	38
1.7.5	Emergency Procedures for FDOT Fueling Facilities.....	39
1.7.6	Commercial Fueling Facilities.....	40
1.7.7	Office of Maintenance Responsibilities .....	40
1.7.8	District Responsibilities.....	40
1.8	Disposal	
1.8.1	General.....	40
1.8.2	Procedure for Disposal of Mobile Equipment at Auction.....	41
1.8.3	Procedure for Disposal of “No Value” Mobile Equipment.....	42
1.8.4	Report of Theft, Loss, or Vandalism of Mobile or Non-Mobile Equip.....	42
1.9	Accidents and Damage Reporting.....	43
1.9.1	General.....	43
1.9.2	Responsibilities.....	43
1.9.3	Accident Reporting.....	43
1.9.4	Accident Investigation.....	44
1.10	Smoking in Department Vehicles.....	45
1.11	Mobile Equipment Operating Rates	
1.11.1	Purpose.....	45
1.11.2	Responsibilities.....	45
1.11.3	Components of Rate.....	45
1.12	Use of DOT 1	
1.12.1	General.....	47
1.12.2	Procedure.....	47
1.12.3	Regulations.....	48
1.12.4	Operating Instructions.....	48
1.12.5	Service Instructions.....	49

---

## Chapter 2 - FLEET QUALITY ASSURANCE

2.1. General.....	50
2.2. Definitions.....	50
2.3. Responsibilities	
2.3.1. Office of Maintenance.....	50
2.3.2. Districts/Units.....	51
2.4. Fleet Quality Components.....	51
2.5. Fleet Quality Assurance Program Reqs and Compliance Indicators.....	51

## Chapter 3 - FLEET EQUIPMENT MANAGEMENT INFORMATION SYSTEMS

3.1. Purpose.....	52
3.2. Mobile Equipment Numbers	
3.2.1. FLAIR.....	52
3.2.2. FMS.....	52
3.3. Inventory Additions and Deletions	
3.3.1. FLAIR.....	53
3.3.2. FMS.....	53
3.4. Correcting or Changing FLAIR Data.....	53
3.4.1 Changing FLAIR.....	53
3.5. Mobile Equipment Utilization Reporting	
3.5.1. Daily Logs.....	54
3.5.2. Mobile equipment Included.....	54
3.5.3. Responsibilities for Completion.....	54
3.5.4. Forms	
3.5.4.1. Daily Log and Monthly Report Form No. 400-000-55.....	54
3.5.4.2. Daily Maintenance Crew Report Form No. 325-010-01.....	55
3.5.4.3. Processing.....	55
3.6. Fuel Use Records	
3.6.1. Fueling at Commercial Vendors.....	55
3.6.2. Fueling at DOT Facilities.....	55
3.6.3. Fuel Data Accuracy .....	56

3.7. Department of Management Services FMS Reports	
3.7.1. General	56
3.7.2. Standard Reports	56
3.7.3. Exception Reports	56
3.7.4. Inventory Reports	56
3.7.5. Utilization Reports	56

## **Chapter 4 - SHOP OPERATIONS**

4.1. General	57
4.2. Preventive Maintenance	57
4.3. Repair and Modification	58
4.4. Shop Work Orders	
4.4.1. General Information	59
4.5. Report of Mobile Equipment Awaiting Service	60
4.6. Mobile Equipment Delivery, Inspection, and Acceptance	60
4.7. Shop Maintenance and Repair Service Rates	62
4.7.1. Purpose	62
4.7.2. Components	62
4.7.3. Application	63
4.7.4. Responsibilities	63
4.7.5. Methodology	63
4.7.5.1. Detail Methodology	63
4.7.5.2. Overview and Example	64
4.8. Vehicle Equivalent Unit	69
4.8.1. Example of VEU Development	70
4.8.2. Example of Application	70

<b>APPENDIX</b>	<b>71</b>
-----------------	-----------

## Chapter 1

### MOBILE EQUIPMENT POLICY AND PROCEDURE

#### PURPOSE

To prescribe uniform procedures, standards, and accountability for the specification, procurement, identification, use, management, maintenance, and disposal of titled, registered vehicles, watercraft, and equipment (Mobile Equipment) by the Florida Department of Transportation (Department).

#### AUTHORITY

Sections 20.23(3) (a), 287.14, 287.17, 287.151, 334.044(2) and 334.048(3), Florida Statutes (F.S.), and Rule 60B-1, Florida Administrative Code (F.A.C.).

#### SCOPE

The Office of Maintenance is required to maintain this **Manual** and provide updates as changes occur. The District Maintenance Engineer/Administrator is responsible for ensuring that all guidelines and operating procedures are adhered to within his or her Districts.

#### REFERENCES

Topic No. 001-000-001, Distracted Driving  
Topic No. 001-010-015, Tobacco Use Policy  
Topic No. 001-260-001, Quality Assurance and Quality Control  
Topic No. 250-000-010, Driver's Record Requirements  
Topic No. 350-040-001, Reporting Vehicle Fringe Benefits  
Topic No. 350-090-310, Tangible Personal Property  
Topic No. 375-040-020, Commodities and Contractual Services Procurement Manual  
Topic No. 400-000-005, Fuel & Maintenance Card  
Topic No. 500-000-015, Loss Prevention Manual

#### TRAINING

None required.

#### FORMS

Forms referenced in **Chapters 1, 2, 3, and 4** of this **Manual** are available from the Department's Forms Library.

## **ABBREVIATIONS**

1. DFM - District Fleet Manager
2. DHSMV - Department of Highway Safety and Motor Vehicles
3. DMEA - District Maintenance Engineer/Administrator
4. DMS - Department of Management Services, Bureau of Motor Vehicles and Watercraft Management
5. FDOT - Florida Department of Transportation
6. FLAIR - Florida Accounting Information Resource
7. FMS - Fleet Management System (provided by DMS)
8. MMS - Maintenance Management System
9. MEOEM – Maintenance Engineer/Operations Engineer/Manager
10. OOM - Office of Maintenance

## 1.1. GENERAL RESPONSIBILITIES

**1.1.1. The Office of Maintenance** shall have the following responsibilities, in accordance with **Chapter 20, Florida Statutes** and related management policies and guidelines.

- 1.1.1.1. Set policy and promulgate procedures for all mobile equipment related matters for the FDOT statewide.
- 1.1.1.2. Coordination and management of mobile equipment funding and replacement.
- 1.1.1.3. Review and approve all mobile equipment acquisitions.
- 1.1.1.4. Coordinate training of personnel whose positions primarily relate to mobile equipment.
- 1.1.1.5. Quality assurance of all mobile equipment related matters statewide. This includes approval and monitoring of the Fleet Quality Control program and activities.
- 1.1.1.6. Coordinate the following mobile equipment related activities with the Office of Maintenance Roadway Section, which shall be responsible for their accomplishment.
  - a) Gathering and analyzing data relating to utilization, down time, operating cost, and other information necessary for the management of the FDOT mobile equipment fleet.
  - b) Coordination of Fleet Information Management Systems.
  - c) Any other mobile equipment related function which the Office of Maintenance determines is better handled centrally to maximize the effectiveness and efficiency of FDOT fleet operations.
  - d) Management of the statewide Automated Fuel System, including fuel system maintenance contracting and data collection.

**1.1.2. The District Maintenance Engineer/Administrator (DMEA)** assisted by the District Fleet Manager (DFM) and District Property Delegate, shall be responsible for:

- 1.1.2.1. Ensuring all Office of Maintenance policies and procedures are properly executed.
- 1.1.2.2. Review of mobile equipment assignment application, mobile



equipment requirements, and utilization (both miles and days used). Ensure compliance with fleet policy and procedure and maximize sharing opportunities within and across districts.

- 1.1.2.3. In cooperation with other districts and the Office of Maintenance and in coordination with FDOT's statewide emergency response system, review vehicle mobile equipment emergency response needs and develop a statewide plan to maximize response capability while minimizing owned mobile equipment requirements.
- 1.1.2.4. In cooperation with other districts, participate in the review of common mobile equipment assignments statewide and provide input to the Office of Maintenance on common mobile equipment specifications for statewide use.
- 1.1.2.5. Prompt reassignment or disposal of all mobile equipment that are not fully utilized.
- 1.1.2.6. Timely and accurate recording of data in accordance with policy and practice in all fleet information systems.
- 1.1.2.7. Purchase of mobile equipment in compliance with Office of Maintenance policy and procedure. This includes analysis of mobile equipment needs and utilization.
- 1.1.2.8. Disposal of mobile equipment in compliance with Office of Maintenance policy and procedure.

**Maintenance Engineer/Operations Engineer/Manager (MEOEM)** are responsible for mobile equipment maintenance shops located in their area. Specific mobile equipment related responsibilities include:

- 1.1.2.9. Adhering to all mobile equipment policies and procedures.
- 1.1.2.10. Maintenance and repair, in accordance with all required procedures and schedules, of all mobile equipment assigned to area shops, as well as other FDOT mobile equipment on travel status within their service area.
- 1.1.2.11. Inspection of new mobile equipment arriving at area shops for conformance to purchasing specifications.
- 1.1.2.12. Preparation of new mobile equipment for assignment and use.
- 1.1.2.13. Review of mobile equipment assignment application, mobile

equipment needs, and utilization (both miles and days used). Ensure compliance with fleet policy and procedure, maximize sharing opportunities within and across districts, coordinate needs for new mobile equipment with the DMEA or his or her designee, and surrender for disposal all mobile equipment which is not utilized in accordance with **Chapter 1, Section (5)** of this **Manual**.

- 1.1.2.14. Provide all required mobile equipment data information accurately and on schedule. Respond promptly to any special requests for mobile equipment information.
- 1.1.2.15. Provide space and security for mobile equipment stored in a holding unit for disposal.
- 1.1.2.16. Provide for an efficient, supportive warehouse operation for mobile equipment needs. A close liaison between warehouse and shop personnel must be maintained.
- 1.1.2.17. Regularly review shop productivity and take actions necessary to ensure staffing is appropriate for work required and productivity targets are met.

**1.1.3. Mobile Equipment Operators** shall have the following responsibilities:

- 1.1.3.1. Adhering to all mobile equipment policies and procedures.
- 1.1.3.2. Performing safety inspections in accordance with the checklists provided and reporting discrepancies immediately to supervision.
- 1.1.3.3. Ensuring that preventive maintenance is performed on schedule and when the need for unscheduled repairs arises, ensuring the mobile equipment is immediately brought to the shop for repair.
- 1.1.3.4. Operation of the mobile equipment in accordance with applicable laws and FDOT regulations and in a safe and efficient manner. Adhering to the requirements of **Topic No. 001-000-001, Distracted Driving** (Link: <https://fdotewp2.dot.state.fl.us/ProceduresInformationManagementSystemIntranet/Procedures/ViewStaticDocument?topicNum=001-000-001> )
- 1.1.3.5. Keeping mobile equipment clean and free of excessive clutter inside the cab and in the cargo area and toolboxes as applicable.
- 1.1.3.6. Possessing a correct and current operator license and FDOT

certifications, if required.

- 1.1.3.7. Completing utilization logs as required in **Chapter 1, Section (5)** of this **Manual**.
- 1.1.3.8. For individual mobile equipment assignments, taking all actions possible to increase efficient utilization of assigned mobile equipment by sharing use with other FDOT employees.

#### **1.1.4. Maintenance Shop Personnel**

- 1.1.4.1. Adhering to all mobile equipment and maintenance shop policies and procedures.
- 1.1.4.2. Completing repair order data entry in accordance with policies and procedures.
- 1.1.4.3. Entry of actual time expended for each task on repair orders.

## **1.2. ASSIGNMENT OF VEHICLES**

### **1.2.1. Standard Passenger Carrying Vehicles**

The Department's passenger carrying mobile equipment fleet includes a variety of vehicles and options. The purpose of this section is to set standards for the assignment and utilization of the most cost-effective mobile equipment item to accomplish the work. Secondary objectives are the elimination of an unnecessarily wide variety of mobile equipment in the fleet, which diminishes the ability to share mobile equipment and complicates servicing, parts supply, and maintenance. These provisions shall apply regardless of the source of funding for the purchase of mobile equipment.

### **1.2.2. Vehicle Standardization**

- 1.2.2.1. The type of vehicle assigned to a position/work application and the accessories with which it is equipped are to be in accordance with the following standardized vehicle procurement lists updated by the Office of Maintenance. Any variation from the vehicle as listed on the following list requires prior approval by the Office of Maintenance.

#### 1.2.2.2. Vehicle Groups

##### Automobiles or Cars Commodity Code No. 25101503

The specification covers the State of Florida requirements for AUTOMOBILES standard fuel or alternate fuel. These vehicles will be primarily used to transport up to 5 people and limited cargo in the State of Florida on typical federal, State, county, and city highways and roads (improved and unimproved), and shall be designed to operate under typical environmental conditions encountered in the State.

##### Light Trucks or Sports Utility Vehicles; Subgroups A-B Sport Utility Vehicles Commodity Code No. 25101507

The specification covers the State of Florida requirements for SPORT UTILITY VEHICLES, 2WD or 4WD standard fuel or alternate fuel. These vehicles will be primarily used to transport up to 5 people and cargo in the State of Florida on typical federal, State, county, and city highways and roads (improved and unimproved), and shall be designed to operate under typical environmental conditions encountered in the State. Justification is required.

##### Light Trucks or Sports Utility Vehicles; Subgroups C-D Truck, Under One Ton Pickup Commodity Code No. 25101507

The specification covers the State of Florida requirements for TRUCKS, UNDER ONE TON, PICKUP, 2WD or 4WD standard fuel or alternate fuel. These vehicles will be primarily used to transport up to 5 people and cargo in the State of Florida on typical federal, State, county, and city highways and roads (improved and unimproved), and shall be designed to operate under typical environmental conditions encountered in the State. Justification is required.

##### Light Trucks or Sports Utility Vehicles; Subgroups E-H Truck, One Ton Pickup and Chassis-Cab Commodity Code No. 25101507

The specification covers the State of Florida requirements for TRUCKs, ONE TON, PICKUP, CHASSIS-CAB, 2WD or 4WD standard fuel or alternate fuel. These vehicles will be primarily used to transport up to 5 people and cargo in the State of Florida on typical federal, State, county, and city highways and roads (improved and unimproved), and shall be designed to operate under typical environmental conditions encountered in the State.

Minivans or Vans Commodity Code No. 25101505

The specification covers the State of Florida requirements for VANS, PASSENGER, VANS, CARGO, CUTAWAY, 2WD standard fuel or alternate fuel. These vehicles will be primarily used to transport up to 8 people and cargo in the State of Florida on typical federal, State, county, and city highways and roads (improved and unimproved), and shall be designed to operate under typical environmental conditions encountered in the State.

Product and Material Transport Vehicles Commodity Code No. 25101600

The specification covers the State of Florida requirements for TRUCKs, GREATER THAN ONE TON & LESS THAN TWO TONS, CHASSIS-CAB, 2WD or 4WD standard fuel or alternate fuel. These vehicles will be primarily used to transport up to 5 people and cargo in the State of Florida on typical federal, State, county, and city highways and roads (improved and unimproved), and shall be designed to operate under typical environmental conditions encountered in the State.

**NOTE:** *Vehicles within each commodity code may change each year as a result of vehicle contract negotiations by the DMS Purchasing Division. The Office of Maintenance shall issue updated list when this information is available.*

- 1.2.2.3. Requests for approval to procure or assign other than the standardized listed vehicle must include specific work-related reasons for the request. Items such as number of persons normally carried, towing capacity required, amount of off-road use, volume

and weight of material carried, and any special needs must be documented and transmitted to the Office of Maintenance Roadway Section.

- 1.2.2.4. Vehicles must be initially ordered with all necessary options for its intended purpose, using the standardized vehicle procurement list. All options and vehicles selected must be the most economical choice to safely and adequately meet Department requirements. The addition of aftermarket accessories requires prior approval by the Office of Maintenance using the process in **Section 1.2.2.1** above. This requirement does not apply to routinely necessary custom modifications such as optical warning devices, survey rod holders, toolboxes, and cone racks.

### 1.2.3. Vehicle Assignment Policy

#### 1.2.3.1. General

- a) All FDOT vehicle assignments and use shall be in accordance with **Rules 60B-1.004, 60B-1.005, 60B-1.006, 60B-1.007, 60B-1.008, F.A.C.; sections 287.16 (1), 287.17, 287.20, F.S.;** and all other applicable **Florida Statutes** and **Rules**. Any provisions stated in this **Manual** shall be subordinate to **Florida Statutes** and **Rules** if a conflict exists.
- b) Vehicles are to be utilized only for necessary State business and only when use of a state-owned vehicle is the most cost-effective means of travel. In addition to state owned vehicle use, reimbursement for use of personal vehicles, rental of vehicles for short term and periodic use, and public transportation should all be considered when determining the most cost-effective means of travel. Generally, State vehicles should be utilized for the type of work they were specified for, and should constantly be in use during working hours, except when being serviced or repaired.
- c) The standard assignment for FDOT vehicles is to a motor pool at a given location. To maximize the use of State-owned vehicles and avoid large amounts of idle time, short term rental contracts should be secured for use on an as needed basis to ensure front line vehicles of adequate capacity are readily available whenever required. See **Section 1.5** for mobile equipment utilization requirements.

- d) Assignment of a vehicle to an individual or position is authorized only when stipulated in Office of Maintenance policy or when the position requires daily travel of more than 4 hours per workday. Employee's assigned vehicles are required to share their assigned vehicles with others and with vehicle pools whenever possible. Employees are reminded that all vehicles are the property of the State and secured for the use of the Department, and not the individual.
- e) No personalization of vehicles is permitted. Employees are prohibited from adding equipment or otherwise altering the vehicle. This prohibition includes, but is not limited to, add-on items such as aftermarket wheel covers; chrome trim; air dams; window film; sound systems and/or speakers; custom paint, such as pin stripes and names painted on doors; and all other customizing accessories.
- f) The personal use of State vehicles and mobile equipment is prohibited except for occasional *de minimis* personal use which may be specifically authorized in writing by the District Secretary or his or her designee and only when such trips are in the best interest of the Department. Use of a State-owned vehicle between home and office (commuting) requires prior approval from the Cost Center Manager and may be approved only under one or more of the following conditions:
  - Employee is departing upon or returning from an official trip away from his or her headquarters and his or her home is in route to/from their headquarters.
  - Employee needs to use the vehicle after completion of his or her regular workday to conduct State business on the same day or before his or her usual working hours on the next day.

An employee that uses a State provided vehicle to commute between their home and work may be required to report a Taxable Vehicle Fringe Benefit, see procedure **Topic No. 350-040-001, Reporting Vehicle Fringe Benefits** (Link: <http://fdotewp2.dot.state.fl.us/ProceduresInformationManagementSystemIntranet/Procedures/ViewStaticDocument?topicNum=350-040-001> )

#### 1.2.3.2. Pool Vehicle Assignment (DMS Class A)

- a) All FDOT vehicles not otherwise assigned will be given a pool assignment. These vehicles will be made available for specific trips and returned to the pool upon completion of the trips. Retention of these vehicles for other purposes or holding them at an office other than the pool location is not permitted.
- b) Vehicles are to be requested and held only for the time necessitated by the job assignment. The practice of reserving pool vehicles in advance of need or delaying their return after the job assignment is complete is prohibited. All employees are expected to request, secure, and return vehicles in a timely manner that is consistent with work need. Pool managers are expected to actively manage pool utilization. Employees are expected to pick up and return vehicles on schedule.
- c) Each operator is responsible for performing safety checks. The person operating the vehicle, when preventive maintenance comes due, is responsible for either having the service performed or informing the pool manager.
- d) Pool vehicles may not be driven to an employee's home unless doing so is specifically pre-approved by the District Secretary or his or her designee as being in the best interest of the State and is for one or more of the following reasons:
  - Employee is departing upon or returning from an official trip away from his or her headquarters and his or her home is in route to/from their headquarters.
  - Employee needs to use the vehicle after completion of his or her regular workday to conduct State business on the same day or before his or her usual working hours on the next day.

#### 1.2.3.3. Limited Use Assignment (DMS Class B)

- a) Employees who have a need for a vehicle for at least 15 days a month (regardless of length of workweek) and 500 miles per month, averaged for the year, may, at the discretion of their District Secretary, Turnpike Director, or cognizant Assistant Secretary, and subject to vehicle availability and other restrictions, qualify for "limited use assignment" of a vehicle. All such assignments shall be recorded and kept up to date by the



District, or, for statewide and central offices, by the Office of Maintenance. The assigned individual will be responsible for the vehicle and will have priority use of it. The vehicle shall normally be parked at the office of the individual overnight or when not in use. Parking the vehicle at another location in order to reduce the use of personal vehicles for commuting at the expense of State vehicle mileage is not permitted. **Rule 60B-1.007, F.A.C.**, regarding taking these vehicles home may be viewed at the following link (Link: [https://www.flrules.org/gateway/RuleNo.asp?title=MOTOR VEHICLES AND WATERCRAFT ACQUISITION, ASSIGNMENT AND USE&ID=60B-1.007](https://www.flrules.org/gateway/RuleNo.asp?title=MOTOR_VEHICLES_AND_WATERCRAFT_ACQUISITION_ASSIGNMENT_AND_USE&ID=60B-1.007) ).

- b) Limited use assignment vehicles may not be driven to an employee's home unless specifically pre-approved by the District Secretary or designee as being in the best interest of the State and is for one or more of the following reasons:
  - (1) Employee is departing upon or returning from an official trip away from his or her headquarters under circumstances which make it impractical to use other means of transportation.
  - (2) Employee needs to use the vehicle after completion of his or her regular workday to conduct State business on the same day or before his or her usual working hours on the next day.

#### 1.2.3.4. Special Assignment Vehicles - Law Enforcement (DMS Class C)

There are no Law Enforcement Offices or vehicles authorized to be used for Law Enforcement in the FDOT.

#### 1.2.3.5. Special Assignment Vehicles - Emergency Service (DMS Class E)

The FDOT recognizes only one type vehicle assignment which permits a non-law enforcement vehicle to be driven to an employee's home on a regular basis. This is when the employee is subject to emergency calls from their residence for the protection of life or property. All such assignments shall be approved by the District Secretary, Turnpike Enterprise Executive Director, or cognizant Assistant Secretary annually. All such assignments shall be recorded and kept up to date by the DFM. The Office of Maintenance shall compile an annual survey of such vehicles.

1.2.3.6. Perquisite Vehicles (DMS Class C)

There are no vehicles authorized to be used as perquisites in the FDOT. All personnel are cautioned not to use, award, or condone the use of vehicles as disguised perquisites. Perquisites must be officially authorized by the DMS.

**1.2.4. License, Operation, and Record Requirements**

- 1.2.4.1. The procedure **Topic No. 250-000-010, Driver's Record Requirements**, may be viewed at the following link (Link: <http://fdotewp2.dot.state.fl.us/ProceduresInformationManagementSystemIntranet/Procedures/ViewStaticDocument?topicNum=250-000-010> ).

All Department managers are required to read and adhere to the procedure. Any person who drives in the course of their employment with the Department must read the procedure BEFORE driving and ensure that they are continually in compliance.

When a consultant or contractor's employee is authorized to drive a Department vehicle per the terms of the contract, the consultant or contractor's employee must also complete the Fuel and Maintenance Card training and sign the **Fuel and Maintenance Card User Agreement, Form No. 400-000-05** before using a Department vehicle.

## 1.3. REPLACEMENT OR ADDITIONAL VEHICLES AND MOBILE EQUIPMENT

### 1.3.1. Funding

Funds may be provided by the Legislature each fiscal year for the acquisition of vehicles and mobile equipment by the FDOT. The amount of such funds, if any, will vary from year to year. An important distinction is made between replacement and additional mobile equipment. **Section 287.14, F.S.**, prohibits the continued use of any vehicle for which replacement funds have been appropriated and replacement vehicle has been placed in service. Additional vehicles must be specifically authorized by the Legislature. This is done by Budget Issue Request according to instructions by the FDOT Budget Office.

Funds for additional vehicle and mobile equipment purchases are routed to the requesting District without change. Funds for replacement of vehicles will be allocated to the Districts by the Office of Maintenance based upon the current FDOT replacement plan.

These accounts will be monitored by the Office of Maintenance. Districts will cooperate by submitting information on these accounts to the Office of Maintenance.

### 1.3.2. Vehicle Replacement and Addition Process

- 1.3.2.1. General - The Office of Maintenance will provide for and coordinate the annual process of securing new Department vehicles and replacing current Department vehicles, including the selection of which vehicles are to be replaced and the type of replacement unit.

The annual process will follow the requirements of **Rule 60B-1.002 Class Equipment**.

- (1) Motor vehicles and watercraft acquired by purchase, lease, or rental shall be of the smallest class that can safely, adequately, and economically meet the performance and job requirements involved.
- (2) All vehicles must be the most appropriate vehicle (car, station wagon, truck, tractor, crawler, trailer or other class of mobile equipment) to accomplish the tasks for which they will be used. Consideration must be given to the terrain where vehicle is normally operated, type and amount of equipment carried, job

duties of individual, economy of operation, maintenance, and other valid considerations. The accessories and options specified for motor vehicles and watercraft acquired by purchase, lease, or rental shall be limited to those which are essential to job requirements or beneficial to safety, efficiency, economy, or energy conservation.

The DMEA normally assign to the DFM the task of coordinating the purchase of vehicles and equipment to be delivered in their District. The DFM therefore has the task of analyzing and prioritizing all District vehicle and mobile equipment needs in accordance with Office of Maintenance policy and direction. Input from all District management personnel, including District office heads and MEOEM, should be solicited.

- 1.3.2.2. Methods for Securing Replacement of Additional Vehicles and Mobile Equipment include:
  - a) DMS contract purchases
  - b) FDOT contract purchase
  - c) Non-contract purchases or rentals
  - d) Short term rental contracts (For seasonal, periodic need, or back up)
- 1.3.2.3. DMS Contracts - The DMS Purchasing Division annually negotiates State term contracts for the procurement of cars, vans, pickup trucks, large trucks, and motorized mobile equipment, such as mowing tractors and end loaders.
- 1.3.2.4. FDOT Contracts - FDOT contracts are negotiated and awarded by the FDOT Purchasing Office in cooperation with the Office of Maintenance. When a need exists for an item that is not on a DMS State term contract for FDOT, the District may draft specifications and request review and approval of the specification from the DMS Specialized Services Division. If any resulting contracts are regularly used by the Districts, the Office of Maintenance will update and rebid them as necessary.
- 1.3.2.5. Non-Contract Purchases or Rentals - Non-contract purchases or rentals normally are done through a specification writing and solicitation of bids process. If the Office of Maintenance (or a

District with Office of Maintenance approval) determines that a non-contract item is needed, the Office of Maintenance will determine if a satisfactory specification is on hand. If not, the Office of Maintenance will, in cooperation with the District, draft the specification and request review and approval from DMS Specialized Services Division. The Office of Maintenance will keep a current library of equipment specifications for dissemination to the Districts.

- 1.3.2.6. Short Term Rental Contracts - These contracts for vehicle and mobile equipment rental may be awarded by DMS or the FDOT Purchasing Office in cooperation with the Office of Maintenance. These contracts are for use in seasonal or periodic work projects. They may also be used to provide back up in the event a needed work vehicle is inoperable. A procedure for use of these contracts will be established by the Office of Maintenance whenever such contracts are issued.

### **1.3.3. Standard Specifications**

The Office of Maintenance will lead a team of district and agency representatives (DMEA's and/or DFM's) to review and develop standard vehicle specifications for various department work assignments. The Office of Maintenance will work with the Department of Management Services to secure contract pricing on the various specifications annually.

The Office of Maintenance will review all Department of Management Services (DMS) mobile equipment contracts and will annually issue a list of standardized mobile equipment choices from each DMS contract to the Districts.

### **1.3.4. Approved Replacement List**

Each year the Office of Maintenance will produce a list of vehicles meeting replacement criteria. The list will include vehicle description and current usage. The Office of Maintenance will work with each district to prioritize the replacement list and evaluate continued need for low usage units. If a decision is made not to replace the unit due to low usage, the current unit must be disposed of unless an exception is granted by the Office of Maintenance.

### 1.3.5. Procurement Requisitions

- 1.3.5.1. To initiate a Procurement Requisition for replacement of a vehicle or equipment, all actions and forms required by procedure **Topic No. 375-040-020, Commodities and Contractual Services Procurement Manual** (Link: <http://www.fdot.gov/procurement/CCSPM.shtm> ) must be completed and submitted to the Office of Maintenance by the Districts based upon the prioritized list referenced in **Section 1.3.4** above and the funds allocated in accordance with **Sections 1.3.1 and 1.3.2** above. All submittals shall be in accordance with a schedule set by the Office of Maintenance, which shall be early enough in the fiscal year purchase cycle to allow for review and approval of purchase packages.
- 1.3.5.2. The Office of Maintenance will evaluate each Procurement Requisition for vehicles and mobile equipment submitted by the Districts to ensure compliance with procedure **Topic No. 375-040-020, Commodities and Contractual Services Procurement Manual**. Disapproved purchase transactions may be resubmitted at any time after necessary corrections are made in accordance with the comments and recommendations made by the Office of Maintenance or DMS Bureau of Motor Vehicles and Watercraft Management.

### 1.3.6. Securing Non-Contract Purchases

As indicated above, the Purchasing Office determines the procedures to be followed in the bidding and bid award process. When a non-contract bid process is undertaken, a **Procurement Requisition** is issued. Prior approval of DMS Purchasing is required. The steps to secure a non-contract purchase are as follows:

- a) The DFM consults with the MEOEM, other office management, and the DMEA and determines what items of mobile equipment are to be purchased for the District.
- b) The DFM submits a list of all such non-contract mobile equipment to the Office of Maintenance for compilation into a spreadsheet of the total statewide needs for non-contract mobile equipment. This shall be completed and submitted no later than March 17 of each year for the next fiscal year.
- c) The specification is prepared by the Office of Maintenance. Districts may be asked to draft specifications.

## 1.4. VEHICLE AND MOBILE EQUIPMENT IDENTIFICATION

Note: Section 1.4 applies regardless of the source of vehicle funding.

### 1.4.1. Color

All FDOT “Work Vehicles” shall be painted DOT Yellow. DOT yellow is defined as being color **#13538 of Federal Standard 595**. At the option of the Districts, the tops of these vehicles may be painted white above the windows. The intent of DOT yellow on Department work vehicles is to improve visibility in and near the flow of traffic, to provide a means of quick identification for FDOT supervision and management and high visibility to the public. A work vehicle is defined as mobile equipment which is frequently operated at low speed in the normal flow of traffic, on the right of way, and/or which makes frequent stops, turns, or otherwise deviates from normal traffic flow. All mobile equipment assigned to field crews shall be considered to meet these criteria. Exemption from this requirement will be considered when the vehicle manufacture requires minimum mobile equipment order amounts for DOT yellow or when the color option is not cost effective. All standard sedans are exempt from the requirement to be DOT yellow unless special circumstances exist. Sedans shall be purchased in standard manufacturer's colors. No premium finishes allowed.

### 1.4.2. Conspicuity Marking

FDOT mobile equipment shall have conspicuity markings applied. All mobile equipment shall have red and white conspicuity marking tape and Department identification logos applied. See **Appendix** for illustrations showing patterns for mobile equipment marking tape. Mobile equipment which should have been procured painted DOT yellow but, due to special circumstances, are some other color, shall have conspicuity marking applied as required as if the item was DOT yellow.

### 1.4.3. Description of Logos

The official FDOT logo design has been approved by the Office of Maintenance. There is only one official logo design, and no office, District, or other subdivision of the FDOT shall use any other. The official logo has, in a blue reflective material, the letters FDOT and the Florida peninsula at the end of the letters FDOT. Also, there are two curved lines at the bottom of the logo connecting to the Florida Keys on the peninsula in a red reflective material. See example:



There are two sizes of the FDOT logo: “large”, 16 inches wide by 8 inches tall, and “small”, 10 inches wide by 5 inches tall.

### 1.4.4. Numerals

There shall be two sizes of vehicle identification numerals: “large”, 3 inches, and “small”, 1 inch high. The large numerals shall be black on reflective yellow background. The small numerals shall be black on a silver background.

### 1.4.5. Location of Marking

Location of markings shall be based on vehicle type as follows:

- a) Large trucks and trailers: See **Appendix** for illustrations showing patterns for vehicle marking tape on these types of vehicles.
- b) On dump trucks a single 2-inch-wide, red/white strip of reflective tape extends all around the item, approximately at 4 feet height. The edge of the red sheeting cannot be located any closer than 3 inches to an amber lamp. The edge of the white sheeting cannot be located any closer than 3 inches to a red lamp. On the front, the tape will generally be applied to the upper portion of the bumper even though this does not meet the height requirement. The rear end is outlined from approximately 4 feet height to the limits of the area presented. The under-ride device shall be marked full length with 2-inch-wide red/white reflective tape.
- c) Where practical, tape should be placed in recesses and protected



areas, provided that it is still highly visible. Gaps in the tape where structural members protrude, or the configuration does not readily lend itself to tape application are normal.

- d) Closed trailers shall have their upper rear corners outlined with 12-inch lengths of white reflective tape, and lower rear with 2-inch-wide red/white reflective tape. The under-ride device shall be marked full width with 2 inch wide red/white reflective tape.
- e) A large FDOT logo shall be placed approximately centered on each front door of trucks. A large logo shall be placed on both sides of trailers; a small logo is permissible only if space cannot be found for a large size.
- f) Large numerals shall be placed on mobile equipment that does not have a tag. Tractors, excavators, skid steer loaders and others will display the department fleet number. The location depends on the mobile equipment configuration.
- g) Vans, pickups, utility, and similar vehicles: On vehicles which, due to their low height, do not lend themselves to marking at the 4 feet height, a single 2-inch-wide strip of red/white reflective tape shall be applied as high on the sides as practical. These vehicles shall have a 1 inch red/white strip applied to the rear bumpers. The front bumper can only have a 1 inch amber/white strip applied. See **Appendix** for illustrations showing patterns for vehicle marking tape on these types of vehicles.
  - Vehicles in this category will have large logos applied to each front door.
  - Non-yellow vehicles will have small numerals on the left rear bumper or lower left corner of the trunk lid.
- h) Construction Mobile Equipment: A single 2-inch-wide strip of reflective tape shall be applied to cause the outer edges of the item from any angle to be illuminated by headlights. This should be at approximately 4 feet height but will vary due to the variety of structures encountered with this class of mobile equipment. All protruding members which might be struck by a vehicle in the dark should be taped. Gaps in the tape where structural members protrude, or the configuration does not readily lend itself to tape application are normal. A triangular slow-moving vehicle emblem (SMV emblem) must be displayed on the rear of vehicles designed for use and speeds less than 25 miles per hour, including all road construction and maintenance machinery. The SMV emblem shall not be displayed on objects which are customarily stationary in use but shall be displayed when such objects are being transported on the roadway of any public highway of this state. See

**Appendix** for illustration and description of the SMV emblem.

- i) If the item of mobile equipment has a cab and doors, a large logo shall be affixed to each door. If the mobile equipment does not have cab doors or other location suitable for a large logo, small logos shall be placed in easily visible locations.
- j) Sedans, vans, pickups, utility, and similar vehicles shall have small numerals denoting the DOT number placed on the left rear bumper or lower left corner of the trunk lid only when the vehicle tag has been replaced.

#### **1.4.6. Vehicle Lighting**

All vehicles with optical warning devices (such as high intensity rotating, flashing, oscillating, or strobe lights) shall have FDOT logos on the front doors for ready identification by the public. Effective with the implementation of this procedure, existing vehicles not in compliance will have logos applied. The optical warning device may be a minimum of one class 1 or 2 warning device that projects amber or white color light in a horizontal 360 degree arc and meets the Society of Automotive Engineers recommended practice **SAE J845** and **SAE J1318**. Also, the device must comply with **Section 316.2397, F.S.** The optical warning device is for use on authorized maintenance or service vehicles to warn of traffic hazards, such as a lane blockage or slow-moving vehicles. These optical warning devices are utilized to capture the attention of motorists and pedestrians and warn of a potentially hazardous activity or situation. Ensure all optical warning devices are installed and properly maintained as recommended by the manufacturer.

Optical warning devices shall be operating when a vehicle is in a work area where a potential hazard exists, i.e., anytime within the clear zone, or while operating the vehicle at less than the average speed for the facility, performing work activities or making frequent stops. The optical warning device shall be unobstructed by ancillary vehicle equipment such as ladders, racks, or booms. If the optical warning device is obstructed, an additional optical warning device is required. To avoid distraction to motorists, do not operate the optical warning device on mobile equipment when they are outside of the clear zone or behind a barrier.

### 1.4.7. License Plates and DOT Numbers

For appearance and efficiency, license plates will not be used on another vehicle after the original vehicle using the plate has been disposed of. When a vehicle is sold, the District shall be responsible for destroying the old license plate by cutting it in half and placing it in a local recycle program. The DFM shall send a letter to the Office of Maintenance attesting to the numbers of plates destroyed. A new license plate will be issued to each new vehicle. All license plates shall be the official State of Florida agency tag with a "DOT" prefix.

DOT numbers will not be "recycled" until they reach 99,999, at which point the series will start over.

## 1.5. MOBILE EQUIPMENT UTILIZATION

### 1.5.1. General

It is expected that mobile equipment will be fully utilized and that districts will regularly review vehicle use and transfer or dispose of underutilized units. FMS is supported by monthly reports from each district compiled from daily reports filled out by each driver. The **Form No. 400-000-55, Daily Log and Monthly Fleet Equipment Report**, and the **Form No. 325-010-01, Daily Maintenance Crew Report**, are the beginning of the information flow that supplies vehicle use data, (such as mileage or hours of use, down-days, idle-days and others) to FMS. Mobile equipment Utilization must be recorded daily in detail by each driver. When the odometer of a vehicle or mobile equipment is replaced, the original reading must be recorded in FMS and accounted when reporting use of the vehicle or mobile equipment with the new odometer.

The MotorLog application is an Office of Information Systems program that provides a web-based input system for vehicle logs. The application has a web-based tutorial for the users. Access to MotorLog requires inclusion in the active directory APP-MEQ-USER security group on each domain.

Also, there are vehicles and mobile equipment assigned to maintenance units that report utilization via the Maintenance Management System (MMS). **Form No. 325-010-01, Daily Maintenance Crew Report**, is the form used by all maintenance units to report mobile equipment use, production, and employee's time. Each report is keypunched at the local yard, stored in a computer, and then compiled into a monthly report

process with the MotorLog data.

### **1.5.2. Identification of Under-Utilized Mobile Equipment**

Each month the Office of Maintenance will produce a target utilization review list. The mobile equipment inventory listed as “active” in FMS, stationary pieces of mobile equipment such as trailers and heavy equipment designated E1- Mission Support or E-3 Emergency Service Support shall be excluded from this utilization review. Mobile equipment that has been in service fewer than twelve months will also be excluded to ensure at least twelve months of data is available for review. The resulting list of “rolling stock” mobile equipment, a target utilization list shall be made up of those items whose calculated average life-to-date mileage use is below 50 percent (“Underutilized”) and greater than 175 percent (“Overutilized”) of the district-wide average utilization for the previous 12 months. The hour meter items must have a minimum threshold of 392 hours. Also, 100 percent of mobile equipment metered in hours must have an average utilization greater than 10 hours for the previous 12 months. The target list will include mobile equipment type and assignment detail, life to date, last fiscal year mileage, and other data relevant to the review of mobile equipment use. This report is available on the FMS report library for monthly review by the DFM.

<b>Utilization for Heavy Equipment Metered in Hours</b>		
Total hours in a year	2,080	52 weeks/yr*4 days/wk*10hrs/day
Holidays per year	90	9 holidays (10 hr days)
leave time used (estimate)	270	6 hrs annual, 4 hrs sick and personal holiday
	<b>1,720</b>	Hours available to work
break time and training	116	Two-15 minute breaks per day and 30 hours annual required training. 172 work days x 0.5 hour + 30 hours = Average for pre-trip & post trip inspections (1 hr/day).
Pre-trip and Post-trip (198 WK Days)	172	172 work days x 1 hour = 172 hours
Safety	12	Hour average safety meeting/month
Drive Time (annual hours)	344	Average drive time to and from the job site or congestion per day (2 hrs/day) (includes materials loading). 172 work days x 2 hours = 344 hours
Mot set-up (on average) (hrs)	172	Average time to set up and take down MOT/day (1 hr). 172 working days x 1 hour = 172 hours.
Emergency/accidents (hrs)	192	Average hours responding to accidents/ incidents per month. 12 months x 16 hours = 192 hours.
Weather conditions (hrs)	240	Average 2 down days due to weather per month. 10 hour day x 2 days x 12 months = 240 hours.
Down time (Repairs) (hrs)	50	Average 5 down days for repairs per year. 10 hour days x 5 days = 50 hours.
Down time (Maintenance) (hrs)	30	Average 3 down days for maintenace per year. 10 hour days x 3 days = 30 hours
	<b>1,328</b>	Hours unavailable to work
<b>Average Annual Available Hours</b>	<b>392</b>	

### 1.5.3. Utilization Review Process

- 1.5.3.1. The DFM will review the utilization report and provide justification for continuation of the assignment of any underutilized mobile equipment on the target list that they believe should be retained in the district. Justification for such continued assignment must be specific and include at least one of the following criteria:
1. Reporting of mobile equipment utilization was in error. The DFM shall take action to have the erroneous information corrected.
  2. Mobile equipment is temporarily replacing other mobile equipment (that is not on the disposal list) that has been damaged and is out of service. The low use mobile equipment will be disposed of as soon as repairs are complete to the other mobile equipment (60 days maximum).
  3. The mobile equipment is a specialized piece of mobile equipment that is needed for emergency response (such as a generator or pump) and the type and location of the mobile equipment has been designated on the department's emergency mobile equipment list.
  4. The mobile equipment is essential to operations, although infrequently used and rental of the mobile equipment or contracting of the service from private sector has been formally shown not to be available or not cost effective. (Note: Details on bid attempts and bid documents are required).
  5. After the DMEA reviews the report, the DFM will designate each mobile equipment for a) disposal, b) transfer to another district, or c) retention by the district. For any mobile equipment coded as (c), a written justification as described in **1.5.3.1** above is required. The coded list and written justifications should be returned to the Office of Maintenance within 30 days of review.
  6. The Office of Maintenance shall review all reports and discuss with the Districts those mobile equipment coded as (c) to be retained.
  7. After review is complete, the DFM will prepare a report for the DMEA with recommendations on which target list mobile equipment should be disposed of, transferred, or retained.

The DMEA shall review the report and determine final disposition for target vehicle. The Office of Maintenance will be notified by the DFM of the actions for each mobile equipment on the target list.

#### **1.5.4. Self Service Motor Pool System**

- 1.5.4.1 General - The Self-Service Motor Pool is an online vehicle reservation system for use by authorized FDOT drivers to reserve FDOT pool vehicles. The system is managed by the DFM and it is comprised of an online reservation site, a kiosk, and automated key box. The concept of the system is to automate the process of reserving and tracking use of pooled vehicles, add unattended vehicle pick-up and drop off, ease the collection of odometer readings from drivers, and manage utilization reports to increase utilization across a smaller fleet of vehicles. The Self-Service Motor Pool system is used to manage all vehicle and user data in one system, have fleet information available to users, and automate preventive maintenance reminders for the DFM. The online application training can be found at the LearningCurve site.
- 1.5.4.2 Grab and Go Local Vehicles at the Kiosk - (Same day use, not for overnight trips)
1. Touch the Kiosk screen to deactivate the screen saver and display the Options Menu. Select the "Grab & Go" button.
  2. The Kiosk will display the login screen. Enter your Username and Password.
  3. Select the type of vehicle by moving the roller ball mouse over the desired vehicle and left click or press the button on the screen.
  4. The Kiosk "Grab & Go" feature defaults the Check Out Vehicle date and time as the current time when you login. You are required to enter the date and time you will be returning the vehicle.
  5. The Kiosk lists the vehicles available. Select the vehicle you need by pressing the "Select" button from the list of available vehicles.
  6. Verify you have selected the correct reservation. If the

reservation is correct, press the "Check Out" button.

1.5.4.3 Make a Reservation Online - The Motor Pool Dispatcher website can be accessed through any browser at: (Link: <https://fldot.agilefleet.com> )

1. Login - After you Login, click the "Make Reservation" link.
2. Select Reservation - for yourself or someone else.
3. Select a Site.
4. Select day and time - Select the day and time you will depart and return the vehicle.
5. Submit the Request - Submit the Request by clicking on the appropriate button. The Motor Pool system will send you an email confirming your reservation, including a summary of your departure and arrival day and time.

1.5.4.4 Check Out a Reserved Vehicle:

1. Touch the Kiosk screen to deactivate the screen saver and display the Options Menu on the Kiosk. Select the "Check Out Vehicle" button.
2. The Kiosk will display the login screen. Enter your Username and Password.
3. The Kiosk will display all reservations made under your Username or all the reservations made for you by another employee. Select the appropriate reservation.
4. Verify you have selected the correct reservation. If the reservation is correct, press the "Check Out" button. If the reservation is not correct, go back to the previous screen by selecting "Check Out a Different Vehicle" option.
5. Open the Key Box by lifting the latch and opening the door. A green light will be lit next to your keys. Remove the key and close the door. Your vehicle is parked at a designated Motor Pool location.



#### 1.5.4.5 Check in a Vehicle:

1. Note the vehicle ending odometer and fuel level before you return the keys to the Kiosk.
2. Touch the Kiosk screen to deactivate the screen saver and display the Options Menu. Click or press the "Check In Vehicle" button.
3. The Kiosk will display the login screen. Enter your Username and Password.
4. The Motor Pool software will display all vehicles checked out by you. Select the vehicle you wish to Check In.
5. If the vehicle is not equipped with electronic odometer data collection, then enter the mileage from the vehicle you wish to Check In. Touch the kiosk screen on the "Mileage In" field and enter your ending mileage. Ending mileage must be entered in the "Mileage" field, regardless of how far the vehicle traveled. Press the "Check In" button.
6. Open the Key Box by lifting the latch and opening the door. A green light will be lit next to your keys slot. Replace the key and close the door. After you replace the key, the Kiosk will log you out of the system.

## 1.6. MAINTENANCE

### 1.6.1. General

- 1.6.1.1. All FDOT mobile equipment has been assigned to FDOT mobile equipment shop for maintenance. All maintenance to be performed on any FDOT mobile equipment shall occur under the direction of the FDOT shop to which it is assigned.
- 1.6.1.2. If emergency repairs away from the normal work area are required, the closest FDOT shop should be contacted. If there are no FDOT shops accessible, commercial shops may be used as an alternative. The operator is required to contact the Cost Center Manager by the next business day following repair to advise of mobile equipment status and provide a copy of the commercial repair order. It shall be the responsibility of the Cost Center Manager to which the item of mobile equipment is assigned to

ensure that it is reported to the appropriate shop. The shop will record the repairs in FMS and a copy of the commercial repair order will be filed by the shop.

- 1.6.1.3. A shop work order in FMS must be completed for all maintenance actions including not only FDOT shop work, but commercially obtained work, operator performed work, warranty work, and factory or vendor recall work, even when no cost to the Department is involved. All repairs, data and information relating to the work performed at FDOT shops shall follow **Chapter 4 (Shop Operations)** of this **Manual**.
- 1.6.1.4. Only FDOT mobile equipment are to be serviced and/or repaired in FDOT shops unless prior authorization from the Office of Maintenance is secured. If mobile equipment from other State agencies stop at an FDOT shop for emergency repair, such as overheating due to a fan belt problem, or a flat tire, the shop should assist as necessary, including performing minor repairs, to get them on the road again. Absolutely no work is to be done on personal mobile equipment in FDOT shops or on FDOT time.
- 1.6.1.5. Mobile equipment operators are required to immediately report mobile equipment problems to the appropriate shop. Mobile equipment must be brought to the shop for repairs as directed by the Shop Superintendent.

## **1.6.2. Maintenance Categories**

- 1.6.2.1. Preventive Maintenance. Currently, the FDOT follows Preventive Maintenance (PM) schedules and utilizes other aspects of a PM system supplied by the Florida Department of Management Services (DMS), Bureau of Motor Vehicles and Watercraft Management with the exception of service check lists. This system is called the Fleet Information Management System (FMS). FMS is a unified system with consistent shop work order, work code entries, and shop file folder information entry conventions. All FDOT shops are required to use this system. See **Chapter 4 (section 4.2 Preventive Maintenance)** in this **Manual** for more information on Preventive Maintenance (PM) schedules.
- 1.6.2.2. Each district is responsible to schedule their PMs. The details of the methods utilized to schedule PM's and the corresponding follow-up process may be determined by each district; however, it is essential that the process ensure timely PM completion and

minimize downtime for both the mobile equipment and the driver.

- 1.6.2.3. It is the responsibility of the MEOEM to ensure that all mobile equipment assigned to a shop over which the MEOEM has authority are serviced on schedule. PM scheduling of non-maintenance mobile equipment must be enforced through appropriate management channels.
- 1.6.2.4. It is the responsibility of mobile equipment operators to ensure mobile equipment are brought to the shop in accordance with PM scheduling requirements.

### **1.6.3. Repair and Modification**

- 1.6.3.1. All emergency repairs and modifications are to be under the direction of the Shop Superintendent of the shop to which the mobile equipment is assigned. It shall be the Shop Superintendent's decision to perform the work in the shop or contract it to a commercial source. Such decisions shall be based on the best value for the Department.
- 1.6.3.2. Shop Superintendents are responsible for establishing priorities and scheduling of all repairs, maintenance, and modification of mobile equipment assigned to the shop. (For modifications, engineering assistance should be sought through the DFM.)
- 1.6.3.3. In the event that an emergency repair takes place, operators should follow the process outlined in **Section 1.6.1.2** above.
- 1.6.3.4. Window suncreening material is permitted but must be applied by a commercial vendor of window suncreening material for mobile equipment and cannot be darker than allowed by **Section 316.2953, F.S.** Contact the Human Resources Office if an exemption to how dark the window sunscreening material is required due to an employee medical condition.

### **1.6.4. Trailer towing guidelines**

- 1.6.4.1. Pulling a trailer, whether it is large or small, requires a regular review of the equipment, including the hitch and signals, as well as some extra safety and clearance precautions to ensure a secure drive. Trailers require extra stopping room and forethought when changing lanes, making turns, and backing up. In general, you should be aware of where you are driving with a trailer, and avoid

situations where you might become stuck, or must drive in reverse for long distances.

1.6.4.2. Definitions:

**Base Curb Weight** – this is the weight of the vehicle including a full tank of fuel and all standard equipment. It does not include passengers, cargo, or optional equipment.

**Vehicle Curb Weight** – this is the weight of the vehicle from the manufacture plus any aftermarket equipment.

**Cargo Weight** – includes all weight added to the Base Curb Weight, including cargo and optional equipment. When towing, trailer tongue load or king pin weight is also part of cargo weight.

**GAW (Gross Axle Weight)** – this is the total weight placed on each axle (front and rear) – including vehicle curb weight and all payload.

**GAWR (Gross Axle Weight Rating)** – this is the maximum allowable weight that can be carried by a single axle (front or rear). These numbers are shown on the Safety Compliance Certification Label located on the driver's door or door pillar. The total load on each axle must never exceed its GAWR. Exceeding the Safety Certification Label axle weight rating limits could result in substandard vehicle handling or performance; serious damage to the engine, transmission, or vehicle structure; or loss of control and personal injury.

**GVW (Gross Vehicle Weight)** – this is the Vehicle Curb Weight + cargo + passengers.

**GVWR (Gross Vehicle Weight Rating)** – this is the maximum allowable weight of the fully loaded vehicle (including all options, equipment, passengers, and cargo). The GVWR is shown on the Safety Compliance Certification Label located on the driver's door or door pillar of the vehicle. The GVW must never exceed the GVWR. Exceeding the Safety Certification Label axle weight rating limits could result in substandard vehicle handling or performance; serious damage to the engine, transmission, or vehicle structure; or loss of control and personal injury.

**GCW (Gross Combined Weight)** – is the weight of the loaded vehicle (GVW) plus the weight of the fully loaded trailer.

GCWR (Gross Combined Weight Rating) – this is the maximum allowable weight of the vehicle and the loaded trailer – including all cargo and passengers – that the vehicle can handle without risking damage. (Important: The towing vehicle’s braking system is rated for operation at GVWR, not at GCWR. Separate functional brakes should be used for safe control of towed vehicles and for trailers where the GCW of the towing vehicle plus the trailer exceed the GVWR of the towing vehicle. The GCW must never exceed the GCWR.

Maximum Loaded Trailer Weight – is the highest possible weight of a fully loaded trailer the vehicle can tow. It assumes a vehicle with only mandatory options, no cargo (internal or external), a tongue load of 10–15% (conventional trailer) or king pin weight of 15–25% (fifth wheel trailer), and driver only (150 lbs.). Review the vehicle owner’s manual, the trailer towing guide provided by the dealership for more detailed information or ask for assistance from the district shop personnel.

Tongue Load or Fifth Wheel King Pin Weight – refers to the amount of the weight that a trailer pushes down on a trailer hitch.

Examples: For a 5,000 lbs. conventional trailer, multiply 5,000 by 0.10 and 0.15 to obtain a proper tongue load range of 500 to 750 lbs. For an 11,500 lbs. fifth wheel trailer, multiply by 0.15 and 0.25 to obtain a proper king pin load range of 1,725 to 2,875 lbs.

Do not exceed the GVWR or the GAWR specified on the certification label. Do not use replacement tires with lower load carrying capacities than the originals because they may lower the vehicle’s GVWR and GAWR limitations. Replacement tires with a higher limit than the originals do not increase the GVWR and GAWR limitations. Exceeding any vehicle weight rating limitation could result in serious damage to the vehicle and/or personal injury.

- 1.6.4.3. Trailer towing - Do not tow a trailer until the vehicle has been driven at least 2,000 miles. Towing a trailer places an additional load on the vehicle’s engine, transmission, brakes, tires, and suspension. Inspect these components carefully after towing. The loaded trailer should weigh no more than 2,000 lbs. Do not exceed the GVWR specified on the certification label. Towing trailers beyond the maximum recommended gross trailer weight exceeds the limit of the vehicle and could result in substandard vehicle handling or performance; serious damage to the engine, transmission, or

vehicle structure; or loss of control and personal injury. The GCW of the vehicle and trailer should not exceed GCWR.

- 1.6.4.4. Preparing to tow - Use the proper equipment for towing a trailer and make sure it is properly attached to the vehicle. Review the vehicle owner's manual or the trailer towing guide provided by the manufacture for more detailed information or ask for assistance from the district shop personnel.
- 1.6.4.5. Hitches - Do not use hitches that clamp onto the vehicle bumper. Use a load carrying hitch. You must distribute the load in the trailer so that 10–15% of the total weight of the trailer is on the tongue.
- 1.6.4.6. Safety chains - Always connect the trailer's safety chains to the frame or hook retainers of the vehicle hitch. To connect the trailer's safety chains, cross the chains under the trailer tongue and allow slack for turning corners. If using a rental trailer, follow the instructions that the rental agency provides. Do not attach safety chains to the bumper.
- 1.6.4.7. Trailer brakes - Electric brakes and manual, automatic, or surge-type trailer brakes are safe if installed properly and adjusted to the manufacturer's specifications. The trailer brakes must meet local and Federal regulations. Do not connect a trailer's hydraulic brake system directly to your vehicle's brake system. The vehicle may not have enough braking power and the chances of having a collision greatly increase. The braking system of the tow vehicle is rated for operation at the GVWR not GCWR. Every trailer must have a stop light if the trailer covers the stop lights on the towing vehicle. Every trailer or semi-trailer weighing 3,000 pounds or more must have brakes which can be operated by the driver in the towing vehicle. The brakes must be designed and connected so that they will automatically stop the trailer if the trailer breaks away from the towing vehicle.
- 1.6.4.8. Trailer lamps - Trailer lamps are required on most towed vehicles. Make sure all running lights, brake lights, turn signals, and hazard lights are working. See the vehicle owner's manual or the trailer towing guide provided by the manufacturer for more detailed information or ask for assistance from the district shop personnel for proper instructions and equipment for installing trailer lamps.
- 1.6.4.9. Limitations on Loading; Securing the Load:

- Do not drive or move any loaded trailer on the highway if the load is not secure. The load must not be able to drop, shift, leak, or otherwise escape.
  - Use a close-fitting cover when hauling loads which could fall or blow onto the roadway. Examples: dirt, sand, lime-rock, gravel, silica, trash, or garbage.
  - Every trailer carrying a load must use proper securing fasteners, including lock chains that securely fasten the load.
- 1.6.4.10. Trailer sway control (IF VEHICLE EQUIPPED) - Turning off trailer sway control increases the risk of loss of vehicle control, serious injury or death. The vehicle manufacture does not recommend disabling this feature except in situations where speed reduction may be detrimental (such as hill climbing).
- 1.6.4.11. When towing a trailer:
- Turn off the speed control. The speed control may shut off automatically when you are towing on long, steep grades.
  - Consult your local motor vehicle speed regulations for towing a trailer.
  - To eliminate excessive shifting, use a lower gear. This will also assist in transmission cooling. (For additional information, refer to the vehicle owner's manual).
  - Anticipate stops and brake gradually.
  - Do not exceed the GCWR rating or transmission damage may occur.
- 1.6.4.12. Servicing after towing - If you tow a trailer for long distances, the vehicle will require more frequent service intervals. Refer to your Scheduled Maintenance Guide of the vehicle for more information or ask for assistance from the district shop personnel.
- 1.6.4.13. The operator is responsible for following all trailer towing guidelines. When making the equipment inspections, any defects identified must be brought to the attention of the district shop personnel for corrective action before towing the trailer.

Trailer towing guidelines:

- Practice turning, stopping, and backing up before starting on a trip to get the feel of the vehicle trailer combination. When turning, make wider turns so the trailer wheels will clear curbs and other obstacles.
- Allow more distance for stopping with a trailer attached. The bottom line is to use caution and slow down.
- If you are driving down a long or steep hill, shift to a lower gear. Do not apply the brakes continuously, as they may overheat and become less effective.
- The trailer tongue weight should be 10–15% of the loaded trailer weight.
- After you have traveled 50 miles, thoroughly check your hitch, electrical connections, and trailer wheel lug nuts.
- Vehicles with trailers should not be parked on a grade. If you must park on a grade, place wheel chocks under the trailer's wheels.
- Avoid "Jackknifing." Jackknifing is named for the position of the vehicle and trailer; this is most common when backing up with a trailer. It is a situation where the angle between the vehicle and the trailer it is pulling is less than 90 degrees, or beyond an L shape to a V shape. Avoid this by never letting the trailer position get beyond the L shape. When reversing with a trailer, just take it slow and get a feel for the trailer. Keep your movement of the steering wheel to a minimum, and remember, you can pull forward to straighten out, so if you are struggling, just start over. Jackknifing will damage the hitch and trailer, so take care to avoid it.
- Launching or retrieving a boat:
  - Disconnect the wiring to the trailer before backing the trailer into the water. Reconnect the wiring to the trailer after the trailer is removed from the water.
  - When backing down a ramp during boat launching or retrieval, do not allow the static water level to rise above the bottom edge of the rear bumper and do not allow waves to break higher than 6 inches above the bottom edge of the rear bumper. Exceeding these limits may allow water to enter vehicle components, causing internal damage to the components and affecting drivability and reliability.



- Notify the district shop personnel if the vehicle rear axle has been submerged in water.

## 1.7. FUEL

### 1.7.1. General

Mobile equipment should be fueled at FDOT fueling facilities whenever practicable. The State issued Fuel and Maintenance card is to be utilized for obtaining fuel.

### 1.7.2. Fuel and Maintenance Card

Fuel cards will be provided for all FDOT mobile equipment. Fuel cards can be provided to the shops for fueling Non-Highway Fixed Asset (NHFA) mobile equipment and newly acquired mobile equipment. Policy and procedures regarding use of the Fuel and Maintenance Card and the responsibilities of the card user, administrator and approver are detailed in procedure **Topic No. 400-000-005, Fuel and Maintenance Card** (Link: <https://fdotewp2.dot.state.fl.us/ProceduresInformationManagementSystem/Intranet/Procedures/ViewStaticDocument?topicNum=400-000-005> ). Every FDOT card user, administrator, and approver shall read the policy in detail and adhere to all its components.

### 1.7.3. FDOT Fueling Facilities

The FDOT fueling facilities at the districts are for fueling department fleet of mobile equipment. All FDOT fueling facilities are required to supply alternative fuels when the supply of these fuels is available. Fuel purchases at FDOT facilities are recorded by the Automated Fuel Dispensing System.

- 1.7.3.1 The following are a set of guidelines that will be followed when a FDOT fuel facility is experiencing fuel card reader equipment malfunction.
- 1.7.3.2 Store and Forward - If the phone line is not operational, the Automated Fuel Dispensing System will go into Automatic Store and Forward feature. This feature will allow transactions to approve locally and will forward all transactions to the Automated Fuel Dispensing System once phone line connection has been re-established.

- 1.7.3.3 Fuel and Maintenance Cards assigned to district shops - The Fuel and Maintenance Card Administrator Issues Department Fuel and Maintenance Cards to Department fleet of mobile equipment. Additionally, the Fuel and Maintenance Card Administrator can issue Department Fuel and Maintenance Cards to Department Shops for the purchase of fuel only at Department in-house fuel sites, except under emergency conditions as stated in **Section 1.2** of procedure **Topic No. 400-000-005, Fuel and Maintenance Card**.

This Fuel and Maintenance Card is for the purchase of fuel for small mobile equipment that is not assigned a Department mobile equipment fleet number. These Fuel and Maintenance Cards will be identified with a number designation 90XXX in FMS. The XXX will designate the FMS District shop number the Fuel and Maintenance Card is assigned. These Administrators are responsible for the issuance and cancellation of all Fuel and Maintenance Cards. Only Department employees may be approvers in the Fuel and Maintenance Card process.

An Emergency Card Profile has been established Department-wide for use only when a State of emergency is issued by Executive Order or Proclamation of the Governor. When a State of emergency is issued, the Emergency Card Profile will be activated to raise the preset limits of the Fuel and Maintenance Card. The Fuel and Maintenance Card Administrator in Central Office will notify the Fuel and Maintenance Card Administrator in the District when the Emergency Card Profile has been activated and de-activated.

- 1.7.3.4 Keypad Access - In the event the magnetic card readers are not operational. The Automated Fuel Dispensing System can be programmed to allow fuel authorization using the keypad.
- 1.7.3.5 Manual Operation - In the event the card reader system is not operational even with telephone assistance from the Automated Fuel Dispensing System contractor customer service representative. The Card Reader system can be bypassed. FDOT personnel will need to manually record all transaction information. FDOT personnel will then need to reconcile the transactions. In the even this procedure is necessary the Automated Fuel Dispensing System contractor customer service will need to instruct FDOT site personnel on how to bypass the

system.

#### **1.7.4 Maintenance of Fueling Facilities**

The following are a set of guidelines that will be followed at a minimum to ensure fuel facility equipment remains operational and free of contamination and compliance issues.

- 1.7.4.1 Bottom samples will be taken at a minimum every 24 months from all tank accesses, automatic tank gauging (ATG) system, and underground storage tank (UST) system for visual inspection.
- 1.7.4.2 Gasoline fuel will be tested for ethanol and ethanol levels will be recorded.
- 1.7.4.3 Diesel fuel will be tested for particulates and other contamination and the levels will be recorded.
- 1.7.4.4 All free water will be pumped from tank leaving fuel behind; fuel will not be taken out with the contamination.
- 1.7.4.5 Any free water left after pump out will be removed by a multistage coalescing system with a medium rating of 1 micron or smaller.
- 1.7.4.6 Particulate and other contamination will be removed from fuel and the tank by a multistage filtration system comprised of a screened strainer basket medium through an explosion proof, hydraulic pump, one 10 micron canister filter medium, one 5 micron canister filter medium, and five 1 micron coalescing mediums.
- 1.7.4.7 Tank walls and tank bottom will be cleaned with a fuel jetting system. Pressure will be variable depending on the tank size, lift, barometric pressure, temperature, and product type. System gallons per minute (G.P.M.) must be regulated manually from 5-300 G.P.M. dependent on contamination type.
- 1.7.4.8 Dead ends of tank will be swept and cleaned with recirculation, fuel jetting and pipe methods.
- 1.7.4.9 Fuel must meet or exceed ASTM standards of quality. Water or other chemicals will not be introduced to the tank system in order to clean the fuel or tank.

- 1.7.4.10 Underground storage tank (UST) minimum service will include the cleaning and lubrication of all sealing surfaces and the cleaning, lubrication, and, if necessary, replacement of all O-rings.
- 1.7.4.11 Automatic tank gauging (ATG) system will be inspected, cleaned, and put back into service.
- 1.7.4.12 All tank accesses will be lubricated and resealed.
- 1.7.4.13 Final clean bottom samples from all tank accesses will be taken at the end of the cleaning processes.
- 1.7.4.14 All waste generated from tank will be stored in approved containers and handled by certified waste handlers. Waste generated will not contain over 5% usable product.
- 1.7.4.15 Street lids will be painted and coded with current industry standard colors.

### **1.7.5 Emergency procedures for FDOT Fueling Facilities**

The bulk fuel used in the FDOT fueling facilities is procured using a Department of Management Service (DMS) state term contract. The Districts must notify the DMS contract administrator when the bulk fuel contract vendor refuses to make a delivery during a State Emergency to a FDOT fueling facility and include the reason for refusal. The following are Emergency procedures for FDOT Fueling Facilities.

- 1.7.5.1 The fuel tanks will be filled to a minimum of 80% capacity within 48 to 72 hours of notification by the FDOT Emergency Management Office of an impending emergency event.
- 1.7.5.2 The fuel levels will be maintained at more than 50% capacity during the emergency event.
- 1.7.5.3 Fuel tank levels will be communicated to the Office of Maintenance if the automated tank monitor equipment is out of service.
- 1.7.5.4 Confirmed fuel deliveries will be communicated to the Office of Maintenance on a daily or more frequent schedule if needed and if the fuel deliveries are during or after normal business hours.

### 1.7.6. Commercial Fueling Facilities

Whenever it is not practicable to access an FDOT fueling station, commercial stations who accept the State's Fuel and Maintenance Card may be utilized. Purchases other than gasoline is limited by procedure **Topic No. 400-000-005, Fuel and Maintenance Card**. Any non-fuel charges made shall be reported to the assigned mobile equipment shop for recording in FMS.

### 1.7.7. Office of Maintenance Responsibilities

Office of Maintenance Roadway section will provide the following:

- a) Assign fuel cards for FDOT mobile equipment assigned to Central Office.
- b) Provide fuel reports generated by the Automated Fuel Dispensing System. These will be available to the District Offices and individual units through the fuel and maintenance card provider.

### 1.7.8. District Responsibilities

The DFM is responsible for the following:

- a) Issuing fuel and maintenance cards for all district mobile equipment.
- b) Monitoring operation of fueling stations throughout the District.
- c) Reporting problems with fueling stations to the Office of Maintenance.
- d) The DFM shall be responsible for checking the accuracy and completeness of commercial and FDOT fuel records.

## 1.8. DISPOSAL

### 1.8.1. General

- 1.8.1.1. FDOT mobile equipment is to be disposed of in accordance with **Chapter 60B-3, F.A.C., - Disposal of Aircraft, Motor Vehicles, and Watercraft**. (Link: <https://www.flrules.org/gateway/Division.asp?DivID=222>)
- 1.8.1.2. Mobile equipment is sold at auction or similar type method as

determined by DMS, unless it is determined that the mobile equipment condition is such that it has little commercial sale value.

- 1.8.1.3. Any mobile equipment that have been replaced must be turned into a district holding unit for disposal within 20 working days after the new mobile equipment is operational and the process for auction detailed in **Section 1.8.2** immediately commenced. The transfer from the current location of the mobile equipment item to the holding unit must be in coordination with the District Property Delegate. The Roadway Section of the Office of Maintenance will maintain a checklist or other means to assure that this takes place.
- 1.8.1.4. Mobile equipment with no commercial value, including those which resale revenues would likely not exceed costs of the normal sale process, shall be disposed in accordance with **Section 1.8.3**.
- 1.8.1.5. Mobile equipment awaiting auction should not have a mobile equipment log submitted. In the FMS inventory, such mobile equipment should be marked with an “N” in the “Log-Required” field. The District Property Delegate, in coordination with the DFM, will update the FLAIR record showing the item is “awaiting auction”.
- 1.8.1.6. All contact with the mobile equipment auction services contractor is handled by DMS, unless specifically authorized under DMS policy and detailed in this **Manual**.
- 1.8.1.7. Mobile equipment awaiting auction that resides on FDOT property is to be provided appropriate security and access control.
- 1.8.1.8. All mobile equipment items awaiting disposal must have all Department logos and numbers removed. Mobile equipment items with a license tag must have the license tag removed and the license tag must be destroyed. Miscellaneous items, debris, or trash should be removed from mobile equipment items awaiting disposal.

## **1.8.2. Procedure for Disposal of Mobile Equipment at Auction**

- 1.8.2.1. The DFM will complete DMS **Form No. MP-6401, Request for Disposal of Mobile Equipment** (Link: [http://www.dms.myflorida.com/content/download/3980/15550/DMS\\_Form\\_MP6401\\_111616.pdf](http://www.dms.myflorida.com/content/download/3980/15550/DMS_Form_MP6401_111616.pdf) ), and forward to DMS and copy the Office of Maintenance, Roadway section.

- 1.8.2.2. When DMS authorizes disposal, the Bureau of Motor Vehicles and Watercraft Management issues transport orders to the contractor auction site. Mobile equipment must be available for pickup immediately when the transport orders are issued by DMS.
- 1.8.2.3. DMS will send the Office of Maintenance an auction sale report as proof of disposal. This report will be sent to the Office of Comptroller and DFM to update the status of the items sold at the auction in FLAIR inventory and FMS inventory.

### **1.8.3. Procedure for Disposal of “No Value” Mobile Equipment**

- 1.8.3.1. If a piece of mobile equipment has no commercial value at auction due to its condition (such as a cannibalized wreck), DMS authorization is required to dispose of it through other means.
- 1.8.3.2. To start the “no value” disposal process, complete DMS **Form No. MP-6401B, Request for Disposal of Equipment without Commercial Value** (Link: [http://www.dms.myflorida.com/content/download/46423/198039/DMS\\_Form\\_MP6401B\\_120816.pdf](http://www.dms.myflorida.com/content/download/46423/198039/DMS_Form_MP6401B_120816.pdf) ), and submit to the Office of Maintenance. The form must be completed and submitted within 10 working days after the equipment is placed in the District holding unit for disposal.
- 1.8.3.3. The DFM will secure DMS approval and advise the Office of Maintenance of further actions required to complete the sale.
- 1.8.3.4. Under NO circumstances should vehicles known to have little sale value be sent through the auction process.

### **1.8.4. Report of Theft, Loss, or Vandalism of Mobile or Non-Mobile Equipment**

- 1.8.4.1. Theft, loss, or vandalism mobile equipment must be reported.
- 1.8.4.2. The DFM will complete **Form No. 350-010-63, Notification of Missing Property** (Link: <https://fms.fdot.gov/Anonymous/SendDocumentToClient?documentId=1832> ) and must notify the District Property Delegate.
- 1.8.4.3. Attach a police report or other form of proof of the incident to the **Form No. 350-010-63, Notification of Missing Property**.

- 1.8.4.4. When vandalism that has caused the mobile equipment to have no commercial value, the DFM shall complete the disposal requirements outlined in **Section 1.8.3** above.

## 1.9. ACCIDENTS AND DAMAGE REPORTING

### 1.9.1. General

Mobile equipment accident and damage actions and reporting requirements are specified in Department procedure **Topic No. 500-000-015, Loss Prevention Manual** (Link: <http://www.fdot.gov/safety/IndustrialSafety/LPM.pdf> ) and must be notified to the District Property Delegate.

### 1.9.2. Responsibilities

- 1.9.2.1. The Department's loss prevention program will be implemented through safety manuals and guidelines promulgated by the State Safety Office based upon the requirements set forth by the State and federal agencies having such authority and jurisdiction.
- 1.9.2.2. All FDOT Employees are to read **Topic No. 500-000-015, Loss Prevention Manual** and to adhere to its requirements.
- 1.9.2.3. All FDOT employees are reminded that a vehicle is state property and an extension of their work environment.
- 1.9.2.4. Supervisors shall be held accountable for ensuring that employees are aware of safety regulations and perform their work in a safe manner.
- 1.9.2.5. Employees are responsible for performing their work in a safe manner and for following established procedures and safe work practices.

### 1.9.3. Accident Reporting

- 1.9.3.1. All mobile equipment accidents that result in personal injury, illness, or property damage shall be immediately reported and investigated in accordance with **Topic No. 500-000-015, Loss Prevention Manual**, regardless of the extent of injury, illness, or property damage. Employees must report accidents within one hour from the time of occurrence to their immediate supervisor or as soon as practicable. Non-fatal accidents are reported by using **Form No. 500-000-15, Vehicle Crash/Incident Report**, (Link:



<https://fms.fdot.gov/Anonymous/SendDocumentToClient?documentId=74> ) and, if necessary, **Form No. 500-000-18, Injury/Illness Report**, (Link: <https://fms.fdot.gov/Anonymous/SendDocumentToClient?documentId=251> ).

- 1.9.3.2. Any accident that results in the fatality of any Department employee shall be reported to the Unit Manager or his/her designee who will contact the appropriate Personnel Officer, District Safety Office, District PIO, and the State Safety Office, Industrial Safety.
- 1.9.3.3. Any incident which results in a fatality on facilities or properties owned, leased, or regulated by the Department must be reported immediately to the respective District Secretary or Assistant Secretary.

#### **1.9.4. Accident Investigation**

- 1.9.4.1. The purpose of an accident investigation is to gather information and record facts about the accident that caused the injury, illness, or property damage and to prevent future recurrences. The investigation should:
  - a) Identify the primary cause(s) and/or contributing factors leading to the accident.
  - b) Determine what, if any, work practices or procedures are involved in the accident.
  - c) Determine what corrective actions can be taken to prevent similar accidents.
  - d) Gather all related information needed to answer the question of what happened, to whom, when, and where.
  - e) Identify person(s) involved in the accident and person(s) who witnessed the occurrence.
  - f) Include an interview of each witness, if possible, which might provide information on the underlying cause(s) of the accident.
- 1.9.4.2. The primary responsibility for conducting the investigation and gathering needed information about the accident rests with the immediate supervisor of the employee involved in the accident or with any other employee designated by the Unit Manager/Office Head for this purpose.

- 1.9.4.3. The investigation of the accident should be initiated immediately. The required reports, **Form No. 500-000-18, Injury/Illness Report and Form No. 500-000-15, Vehicle Crash/Incident Report** must be completed within seven (7) working days of the occurrence. All information gathered from the investigation shall be recorded on the required report form. The report will provide findings regarding the accident to the Unit Manager/Office Head and provide a written record of the interim action(s) or corrective action(s) being taken to prevent similar occurrence(s).

#### 1.10. SMOKING IN DEPARTMENT VEHICLES

In accordance with policy **Topic No. 001-010-015, Tobacco Use Policy**, (Link: <https://fdotewp2.dot.state.fl.us/ProceduresInformationManagementSystem/Intranet/Procedures/ViewStaticDocument?topicNum=001-010-015> ), the use of tobacco products, including “E-cigarettes,” is prohibited in Department mobile equipment.

#### 1.11. Mobile equipment Operating Rate

##### 1.11.1. Purpose

Mobile equipment operating rates are established to estimate costs for the operation of mobile equipment. The billing to operational cost centers is based on actual operating costs and not operating rates.

##### 1.11.2. Responsibilities

- a) The Office of Maintenance, in cooperation with Office of Comptrollers, will determine methodology and develop the rates.
- b) Districts are responsible for maintaining and entering into automated or manual systems accurate data relating to vehicle and mobile equipment operation and maintenance.

##### 1.11.3. Components of Rate

- a) The mobile equipment operating rates will be calculated for each fleet code number and will include the following:
  - Actual depreciation costs

- Actual operating costs, including fuel, oil, repair, and maintenance costs.
  - An indirect or overhead factor that represents actual fleet operations overhead costs. (**Note:** Elements comprising the overhead factor shall be detailed. Elements that are already covered in other department billings may be excluded from the vehicle operating cost).
- b) Rates will be per unit and/or per mile, based on the number of units or actual utilization of all mobile equipment within each fleet code number.
- c) Implementation - Mobile equipment operating rates will be reviewed and adjusted, if necessary, on an annual basis. The mobile equipment operating rates will be used for estimating costs for job cost report purposes and will be used by the Department for recovery of reimbursements due the Department for use of the Department's mobile equipment.

## 1.12. USE OF DOT 1

### 1.12.1. General

The Department's antique truck, "DOT 1", is available for public display and parades under certain conditions. This section gives the procedure for securing this truck and sets forth necessary guidelines for its operation and maintenance. No commercial use by or for the benefit of nonpublic individuals, firms, or institutions shall be made of the mobile equipment.

Authorized Department maintenance personnel are responsible for the use and care of the vehicle under the direction of the Mobile Equipment Manager or designee in the Central Office.

### 1.12.2. Procedure

DOT 1 will be available for special public displays and parades throughout the State under the following guidelines:

1. A list of events, compiled by each District and updated as desired shall form the basis for a calendar for use of DOT 1. This calendar will be maintained by the Mobile Equipment Manager or designee, who has been designated as the "DOT 1 Coordinator." Events which are held annually, the dates of which are subject to change, are not carried to a new calendar year, but renewal requests must be made. Preference in assigning use shall be given to those events previously placed on the calendar.
2. Requests for use of the vehicle shall be made using a copy of *Form No. 400-030-01, Request for Use of DOT 1*, (Link: <https://fms.fdot.gov/Anonymous/SendDocumentToClient?documentId=780>) and received by the DOT 1 Coordinator at least 21 calendar days prior to an event. The request shall be signed by a person holding a position of at least an Office Manager in the Central Office or District Director or higher in a District Office.
3. On the basis of first request received, first considered, the DOT 1 Coordinator shall respond not less than 14 calendar days prior to the event, notifying each requestor whether the vehicle is available and, if available, giving the vehicle's location and other necessary instructions.

**1.12.3.** The following regulations shall be adhered to by users of the vehicle:

1. It is to be driven only by a Department employee with a valid operator's license. Supervision shall be by a Department mobile equipment shop superintendent or foreman.
2. Occupants of the truck are limited to Department employees, public officials, or others as may be authorized by the Secretary of Transportation or his or her delegate's. The number of occupants must not exceed the number authorized by state and local laws and regulations.
3. An enclosed trailer with electric brakes is provided for the transport of DOT 1. A tow truck is not provided. The user shall arrange for a suitable tow truck, which must be a one-ton or larger capacity, with hookup for electric brakes.
4. The user will be responsible for total care and security of the vehicle and trailer, including loading, transporting, unloading, fueling, and cleaning before and after use.
5. The user will make entries on **Form No. 400-000-55, Daily Log & Monthly Fleet Equipment Report**, noting all dates and uses while in the user's care, for both the vehicle and the trailer.
6. Special problems, including breakage, repairs, etc., must be listed by memorandum, with a copy of the shop work order or other documents attached, and furnished to the "DOT 1 Coordinator" in the Office of Maintenance.
7. All repairs and/or parts required must keep the vehicle as near as possible in appearance to the original configuration and be performed in such a manner as to retain a high degree of antiquity.

**1.12.4.** Operating instructions for drivers/operators of DOT 1 are as follows:

1. The truck must, at all times, be operated at moderate speeds and under the conditions applicable to necessary transfer, parades, or test runs. The operator must listen and watch for problems that could cause damage and must discontinue operation if necessary, to prevent damage to DOT 1.
2. Prior to Operating - Each Day:
  - a. Check oil, coolant, and fuel levels and replenish as required.

- b. Perform a walk-around inspection for proper tire inflation, loose or overhanging items and/or accessories. Correct before operating.

3. Starting and Driving Instructions:

- a. Turn fuel valve on, quarter turn counterclockwise, with handle down.
- b. Set ignition lever advance (spark) at quarter down, counterclockwise, at left side of steering wheel.
- c. Set throttle lever at half down (approximately), clockwise, at right side of steering wheel.
- d. Turn ignition key to pop ignition out.
- e. Push starter rod with right toe and as engine turns, quickly lift choke rod until engine fires and release. Do not choke more than two engine turns at a time.
- f. As soon as engine runs, adjust spark lever downward and throttle lever upward to obtain desired idle level.
- g. When engine is turned off for more than very short periods of time, the fuel valve should be turned off (clockwise) one quarter turn.
- h. REMEMBER, the transmission is not synchromesh and shifting comes with clutch-throttle manipulation (double-clutching) and experience.

**1.12.5.** Service Instructions (Minimum)

1. The truck engine lubricating oil is S.A.E. 30 weight, HD, with a minimum API service rating of SG.
2. Fuel should be regular gasoline, minimum octane of 87.
3. Use 25 percent permanent type winter/summer antifreeze solution, flush and renew each year.
4. The truck should be fully serviced at least every six months or more as conditions and use may require.
5. It should be noted that the primary electrical system is 6V, positive ground. If recharging the battery is necessary, remove cables and charge positive to positive and negative to negative, as is normal to recharge batteries.

## Chapter 2 FLEET QUALITY ASSURANCE

### 2.1. GENERAL

It is the policy of the Florida Department of Transportation to use a systematic but flexible approach to Quality Assurance (QA) and Quality Control (QC) to monitor work processes to implement laws, rules, procedures, policies, and standards. This is intended to ensure compliance and quality performance by the Central Office and District units responsible for the delivery of transportation products, services and information. See procedure **Topic No. 001-260-001, Quality Assurance and Quality Control**, (Link: <https://fdotewp2.dot.state.fl.us/ProceduresInformationManagementSystemIntranet/Procedures/ViewStaticDocument?topicNum=001-260-001> ).

Fleet management is a complex business and ensuring the effectiveness of a fleet management program requires a set of requirements and indicators that represent all aspects of service delivery, cost control, safety, and appropriate use. Large fleets generate corresponding large amounts of data—too large to be simply “looked at” with any meaningful result. The use of a series of measures capable of identifying problems or areas for improvement is an essential management tool.

### 2.2. DEFINITIONS

- **Quality** is defined as conformance to valid customer requirements (including laws, rules, procedures, policies and standards).
- **Quality Assurance** is defined as the activity of providing fact-based evidence that quality products, services, and information are being delivered.
- **Quality Control** is defined as the activities of implementing, monitoring, and continuously improving processes to ensure delivery of quality products, services, and information.

### 2.3. RESPONSIBILITIES

**2.3.1.** The Office of Maintenance shall develop, execute, and manage a Fleet Quality Assurance Program for the Florida Department of Transportation mobile equipment fleet. Responsibilities include, but are not limited to:

1. Determination of all measures and analysis required to effectively manage the mobile equipment fleet.

2. Determination of measures for inclusion in the Department's Annual Quality Assurance Monitoring Plan.
3. Scheduling of Quality Assurance Reviews and Inspections.
4. Review of Plan information and measures, determination of actions required for improvement, and execution management.

**2.3.2.** All districts and units are required to collect and provide the data required by the fleet quality assurance program, be responsive to requests from the Office of Maintenance, review and ensure data accuracy, endeavor to meet quality targets, take immediate action on quality review and inspection findings, and actively manage activities associated with quality outcomes.

## **2.4. FLEET QUALITY COMPONENTS**

The Fleet Management Quality Control Program shall contain elements that monitor key fleet management activities and have quality data available to measure effectiveness. The required elements include:

1. General Fleet Management – Activities and outcomes relating to overall cost management, policy dissemination, planning, and service effectiveness
2. Inventory/Availability/Use – Controls and practices relating to inventory management, availability, and use
3. Fleet Management Information – Controls and practices ensuring full and accurate data reporting
4. Maintenance – Practices and outcomes that reflect effective maintenance service delivery

## **2.5. FLEET QUALITY ASSURANCE PROGRAM REQUIREMENTS AND COMPLIANCE INDICATORS**

The requirements and compliance indicators for the Fleet Quality Assurance Program are detailed in the **Appendix** of this **Manual**. It includes detail on the review process and related responsibilities. The measures highlighted are the current fleet management measures. The additional measures are for future revisions of the Fleet Quality Assurance Program.



## Chapter 3 FLEET MANAGEMENT INFORMATION SYSTEMS

### 3.1. PURPOSE

Efficient management of the mobile equipment in FDOT's fleet requires accurate records and data related to mobile equipment location, condition, utilization, fuel use, and operating costs. Good records help make possible appropriate mobile equipment dispatching, minimum idle time, regular maintenance scheduling, utilization review, effective cost management, and timely replacement. For FDOT, the required information is housed in various state systems, including the Florida Accounting Information Resource System (FLAIR), FDOT Maintenance Management System (MMS), DMS Fleet Information Management System (FMS), FDOT Petroleum Accounting System (PETRO) plus FDOT software required to affect the interfacing of the aforementioned systems. The maintenance of these systems is the joint responsibility of the Office of Maintenance, the FDOT Districts, and the DMS Bureau of Motor Vehicles and Watercraft Management.

- 3.1.1. All FDOT mobile equipment is listed in FLAIR and FMS. All mobile equipment must appear in both systems in order for the monthly accounting to be correct.

### 3.2. Mobile equipment Numbers

- 3.2.1. **FLAIR** - Mobile equipment in FLAIR is assigned five-digit numbers with leading zeros as required. FLAIR adds a sixth leading zero digit. FLAIR prefixes mobile equipment with "ME," which stands for mobile equipment. This prefix is used only in FLAIR and has no other application in FMS. The sixth leading zero is used for mobile add-on equipment, which is designated "MA." For example, a hoist mounted on a truck, which might be removed when the truck is sold and re-used on a new truck. The number of the hoist would be MAXXXXXX, where the first X is "1" for the first mobile add-on to that "ME" item, "2" for the second add-on, etc. See also, **Topic No. 350-090-310, Tangible Personal Property**, (Link: <https://fdotwp2.dot.state.fl.us/ProceduresInformationManagementSystemIntranet/Procedures/ViewStaticDocument?topicNum=350-090-310> ).
- 3.2.2. **FMS** - All FDOT mobile equipment in FMS is identified by the prefix "DOT" followed by the assigned five-digit number with leading zeros as required. This is called the "DOT Number" or the "Tag Number" in FMS and ME number in FLAIR. DOT license tag numbers are "chained" to ME numbers in FLAIR and are cross-referenced through a program in the Mobile

Equipment (MEQ) system. All mobile equipment charges are made through the FMS system by DOT number.

### **3.3. Inventory Additions and Deletions**

**3.3.1.** FLAIR - Office of Maintenance is responsible for the non-accounting of mobile equipment and the District Property Delegates are responsible for the accounting information of mobile equipment. Upon completion of the non-accounting, the Office of Maintenance will notify the DFM. The DFM will communicate with the District Property Delegate. District Property Delegates will follow the property procedures to issue MA numbers. The Districts are responsible for monitoring their respective fleet inventories in FLAIR and requesting the Office of Maintenance for transfers from one district to another. Fleet items from Central Office will be transferred to the Districts for disposal process. Statewide Offices, such as Turnpike Enterprise, MCSAW, State Materials, etc., shall ensure that DFM and the Office of Maintenance are informed of any mobile equipment transfer or any other action that would affect inventory, shop assignment, and location assignment. The District Property Delegates are responsible for deletions or disposals in FLAIR. The Office of Maintenance will issue mobile add-on "MA" to mobile equipment in FLAIR as requested by the districts. The DFM is responsible for monitoring their respective fleet inventories and correcting discrepancies between FLAIR and FMS.

**3.3.2.** FMS - The DFM's are responsible for FMS record additions and deletions. Deletions are made when mobile equipment is sold, stolen, or cannibalized. Fleet items from Central Office will be transferred to the Districts for disposal process. Statewide Offices, such as Turnpike Enterprise, MCSAW, State Materials, etc., shall ensure that DFM and the Office of Maintenance are informed of any mobile equipment transfer or any other action that would affect inventory, shop assignment, or mechanic workload. The DFM's are responsible for monitoring their respective fleet inventories and correcting discrepancies between FMS and FLAIR.

### **3.4. CORRECTING OR CHANGING FLAIR DATA**

**3.4.1.** It is necessary to change FLAIR data in the event that:

- Data shown on a report is not correct.
- Mobile equipment is assigned to another shop for service.
- Mobile equipment is assigned to another unit within the District.

It is the responsibility of the District to make necessary changes and correct errors in the FLAIR property file. After making changes, put a “C” in the second space of the FLAIR “Property Unique” field and the date in the fourth through ninth spaces.

Mobile equipment transfers between Districts will be entered in FLAIR by the Central Office Property Delegates. The transfer will occur when the Central Office Delegate receives a PMR from the DFM. For information and requirements relating to bar code decals, refer to procedure **Topic No. 350-090-310, Tangible Personal Property**.

### **3.5. MOBILE EQUIPMENT UTILIZATION REPORTING**

#### **3.5.1. Daily Logs**

FMS is supported by monthly reports from each District compiled from daily reports filled out by operators or job foremen. The MotorLog data entries from **Form No. 400-000-55, Daily Log and Monthly Fleet Equipment Report** and the Maintenance Management System data entries from **Form No. 325-010-01, Daily Maintenance Crew Report**, are the beginning of the information flow that supplies mobile equipment use data; such as mileage or hours of use, down-days, and idle-days to FMS.

#### **3.5.2. Mobile equipment Included**

All mobile equipment that has been assigned a FDOT number is required to have daily usage reports. A report is required for each month the mobile equipment is on inventory, until it has been processed for disposal. Once disposal paperwork has been completed the FMS file must be changed to designate that no log is required. This is done by inserting the letter “N” in the “log required” field.

#### **3.5.3. Responsibility for Completion**

The operator of the individual mobile equipment is required to complete the daily report. However, when a crew of people is working from one mobile equipment or if a group of mobile equipment is being operated by more than one person, the crew supervisor or his designee will fill out the daily report.

#### **3.5.4. Forms**

- 3.5.4.1. Each month the daily entries on **Form No. 400-000-55, Daily Log and Monthly Fleet Equipment Report**, are entered directly into

the MotorLog application by the driver/operator. This must be accomplished by the fifth working day of each month in order to meet DMS Administrative Rules requirements. Districts may require earlier submittal if deemed necessary by the DMEA.

3.5.4.2. The daily entries on **Form No. 325-010-01, Daily Maintenance Crew Report**, are entered directly into the Maintenance Management System (MMS). This form must be used by all maintenance units to report equipment use, production, and employee time.

3.5.4.3. Processing

1. Data for each report in **Section 3.5** above is entered at the local yard, stored electronically, and then compiled into a monthly report.
2. After data entry, all data from the logs and crew reports are edited for errors and inconsistencies. Error listings are sent to the Office of Maintenance and to the Districts for corrective action.
3. After correcting, utilization records are processed by the Office of Maintenance Roadway Section for addition to the monthly data transfer to FMS.

### 3.6. FUEL USE RECORDS

Fuel usage is recorded by State of Florida credit card purchases at commercial stations and through purchases made at FDOT Automated Fuel Dispensing stations at Maintenance yards. Each system is described as follows:

#### 3.6.1. Fueling at Commercial Vendors

Commercial fuel data is received electronically from the State's credit card vendor. Requirements regarding use of this credit card may be found in **Chapter 1, Section (7)** of this **Manual**. Any miscellaneous charges made in accordance with State policy on the credit card shall be reported in writing to the assigned mobile equipment shop for recording on a shop work order in FMS.

#### 3.6.2. Fueling at DOT Facilities

Fuel purchases at FDOT facilities are recorded by the Automated Fuel Dispensing System.

### **3.6.3. Fuel Data Accuracy**

The DFM shall be responsible for checking the accuracy and completeness of commercial and FDOT fuel records.

## **3.7. DEPARTMENT OF MANAGEMENT SERVICES FMS REPORTS**

### **3.7.1. General**

There are a variety of FMS management reports which are available to all levels of management. Standard reports have been preformatted and designed by DMS in cooperation with the Office of Maintenance. They may be retrieved from the FMS by name.

### **3.7.2. Standard Reports**

- a) Mobile equipment Management Summary Report. This report combines three types of reports into one. It summarizes use, operating costs and inventory information for all mobile equipment.
- b) Mobile Equipment Cost and Utilization Summary. This report can be sorted and filtered a number of different ways and is an excellent management tool for obtaining an overview of idle and down time, miles or hours utilized, days idle, days down, maintenance cost, operating cost, and cost per mile or hour. It is recommended that managers run and study these reports frequently for mobile equipment under their cognizance. Districts are required by Quality Assurance Reviews to document that mobile equipment use and costs have been reviewed through such reports every month.

**3.7.3. Exceptions Reports.** Exceptions list only the mobile equipment satisfying the selected reporting criteria.

**3.7.4. Inventory Report.** This report lists all mobile equipment in the Department by number. In addition to the standard reports, special listings can be created. These listings can include only user specified information. However, they may take longer to produce since they must be written to fit each situation. Like the standard reports, these listings are available in several formats.

**3.7.5. Utilization Report.** This report details the idle time and miles or hours of usage in mobile equipment number order. The report can combine several fleet codes on one page, or it can page break between fleet codes.

## **Chapter 4**

### **SHOP OPERATIONS**

#### **4.1. GENERAL**

- a) All repairs, data, and information relating to the work performed at FDOT shops shall be in compliance with this *Manual*.
- b) All FDOT mobile equipment has been assigned to a FDOT mobile equipment shop for maintenance. All maintenance to be performed on any FDOT mobile equipment shall occur under the direction of the assigned shop superintendent.
- c) If emergency repairs away from the normal work area are required, the closest FDOT shop should be contacted. If there are no FDOT shops accessible, commercial shops may be used as an alternative. The operator is required to contact the Shop Superintendent on the next business day to advise of mobile equipment status and to provide a copy of the commercial repair order. It shall be the responsibility of the Cost Center Manager to which the item of mobile equipment is assigned to ensure that the commercial repair order is provided to the appropriate shop. The shop will record the repairs in FMS and a copy of the commercial repair order will be filed by the shop.
- d) A shop work order must be completed for all action of maintenance including not only FDOT shop work, but commercially obtained work, operator performed work, warranty work, and factory or vendor recall work, even when no cost to the Department is involved.
- e) Only FDOT mobile equipment are to be serviced and/or repaired in FDOT shops unless prior authorization from the Office of Maintenance is secured.
- f) If mobile equipment from other State agencies stop at an FDOT shop for emergency repair, such as overheating due to a fan belt problem, or a flat tire, the shop should assist as necessary, including performing minor repairs, to get them on the road again.
- g) Absolutely no work is to be done on personal mobile equipment in FDOT shops or on FDOT time.

#### **4.2. PREVENTIVE MAINTENANCE**

- a) Currently, FDOT follows Preventive Maintenance (PM) schedules and utilizes other aspects of a PM system supplied by the Florida Department of Management Services, Bureau of Motor Vehicles and Watercraft Management, with the exception of service check lists. This system is FMS. This is a unified system with consistent shop work order, work code entries,

and shop file folder information entry conventions. The FMS system is the official program for monitoring and reporting delinquent PMs. All FDOT shops are required to use the FMS system.

- b) The PM system is a three-tiered system, consisting of a PM “A”, PM “B”, and PM “C” service plan. Under this system, the PM “A” is a routine servicing consisting mainly of an oil and filter change, fluid check, and general inspection. Consult mobile equipment manufactures manuals for recommended preventive maintenance intervals. PM “B” adds some service and inspection items and is to be done every third PM “A”. PM “C” is a major servicing and tune-up, including replacement of all belts and hoses. It is done every sixth PM “A”.
- c) The Office of Maintenance, in cooperation with the districts, shall develop a standard list of repairs and inspections to be completed on stated intervals for the PM “A”, PM “B”, and PM “C” service plan. Use this standard list of repairs and inspections as a guide along with the manufacturer's maintenance manual to prevent missing service requirements that would void the manufacturer's mobile equipment warranties. The PM system is a guide which should be used with judgment. The checklists supplied are optional. Not all items on the checklists apply to all mobile equipment and there may be items which should be checked or serviced which are not on the checklist. The checklist should therefore be regarded as a minimum service. See the **Appendix** section for the preventive maintenance checklist.
- d) When performing PMs and inspections, shops shall identify all other required repairs and complete them immediately or schedule them with the mobile equipment driver as appropriate.
- e) The methods utilized to schedule PMs and the corresponding follow-up process may be determined by each district; however, it is essential that the process ensure timely PM completion and minimize downtime for both the mobile equipment and the driver. It is the responsibility of the MEOEM to ensure that all mobile equipment assigned to a shop over which the MEOEM has authority are serviced on schedule. PM enforcement on non-Maintenance mobile equipment through appropriate management channels must be pursued.

### 4.3. REPAIR AND MODIFICATION

- a) All except emergency repairs and modifications are to be under the direction of the Shop Superintendent of the shop to which the mobile equipment is assigned. It shall be the Shop Superintendent’s decision to perform the work in the shop or contract it to a commercial source. Such decisions shall be based on the best value for the Department, with commercial repair and

parts cost compared to cost of completing the repair internally, using the shop labor and parts plus mark-up rates to determine the latter. In addition to the cost differential, the amount of time the mobile equipment would be offline shall also be considered. If special skills or equipment are required for certain repairs or there are cost advantages of volume, a cost benefit for always outsourcing that type of repair should be completed.

- b) Major modifications to a mobile equipment, outfitting with aftermarket specialty equipment, or similarly equipping new or used requires the prior approval from the Office of Maintenance. Intentions of equipping new mobile equipment must be declared at the time of mobile equipment order request.
- c) Shop Superintendents are responsible for establishing priorities and scheduling of all repairs, maintenance, and modification of mobile equipment assigned to the shop. (For modifications, engineering assistance should be sought through the DFM).
- d) All repairs are to be completed in accordance with standard acceptable practices and in compliance with warranty requirements.
- e) All welding on critical components of equipment, the failure of which would jeopardize the safety of personnel or cause more than inconsequential property damage, shall be accomplished in accordance with applicable American Welding Society specifications. This includes the provisions for welder qualification and inspection of welds. Assistance from the Aluminum Fabrication Shop in Oviedo can be requested when welding critical components to mobile equipment.

#### **4.4. SHOP WORK ORDERS**

##### **4.4.1. General Information**

- a) All FDOT numbered mobile equipment must have a work order completed for ANY work by ANY person or entity. This includes Non-Highway Fixed Asset (NHFA) items and small mobile mechanical equipment, such as lawn mowers. For NHFA items and small mobile mechanical equipment, such as lawn mowers, which do not have an NHFA number, use "90XXX" where the XXX is the cost center of the shop to which the item is assigned. The shop work order will be entered by shop personnel into FMS.
- b) All time spent by any FDOT employee (Mechanic, Supervisor, Laborer, etc.), inmate, or contracted individual working on any FDOT mobile equipment must be entered into FMS. The time recorded is to be the actual time expended.



- c) Each repair task is to be coded in accordance with the Repair Code List in FMS.
- d) Any parts utilized in the maintenance and repair of a mobile equipment must be entered into FMS with the associated repair time.
- e) Any repair and maintenance and associated parts secured at a commercial repair shop or other outside vendor must be entered into FMS.

#### **4.5. REPORTING OF MOBILE EQUIPMENT AWAITING SERVICE**

- a) Each Shop will provide instructions to their customers for providing notice to the shop of any piece of mobile equipment that is “down” due to the need for maintenance or repair of any kind. Such notice shall be provided to the shop within one working day of the item being reported “down” by Maintenance crews.
- b) The Shop Superintendent is responsible for scheduling and prioritizing repairs. Repairs must be scheduled within two working days of receiving notice.
- c) If it is determined by the MEOEM or designee that a “down” unit will not be repaired due to age and condition, then actions to dispose of the unit shall be immediately taken in accordance with the disposal requirements detailed in **Chapter 1, Section (8)** of this *Manual*.
- d) If it is determined by the MEOEM or designee that a “down” unit will not be repaired due to insufficient funds to cover the repair cost, then a shop work order shall be opened with the explanation on the work order that the mobile equipment will be repaired when funds are available. The shop work order will remain open until repairs are accomplished. After 6 months, the item shall either be considered for repairs or disposal in accordance with the disposal requirements detailed in **Chapter 1, Section (8)** of this *Manual*.
- e) If a unit that has been repaired is not picked up within 2 working days of notice, the Cost Center Manager of the mobile equipment shall be notified. This will ensure that the mobile equipment is placed in service.

#### **4.6. MOBILE EQUIPMENT DELIVERY, INSPECTION, AND ACCEPTANCE**

When mobile equipment is delivered to the maintenance yard, the Shop Superintendent or designee is responsible for the following:

- a) Accepting delivery. Mobile equipment is not considered delivered until it is on the ground. FDOT personnel should not assist in the unloading, nor should FDOT mobile equipment be used for this purpose unless there is no

other practical alternative. Participating in unloading mobile equipment could result in a claim if an accident occurs during unloading.

- b) Inspection. The DFM is responsible for ensuring that the Shop Superintendent has a copy of the correct specification for the mobile equipment on hand. The Shop Superintendent, or designee, will inspect the mobile equipment to ensure conformance with the specification. This must be done line by line and include any special provisions.
- c) Weight and VIN Verification. For non-DMS contract mobile equipment purchased from out of state dealers, the Vehicle Identification Number (VIN) must be verified by a badged law enforcement officer, a Notary Public, a licensed Florida mobile equipment dealer, or a Department of Highway Safety and Motor Vehicles Inspector. If the item being accepted is a trailer less than 2,000 lbs. gross vehicle weight (GVW) and the weight is not stated on the Manufacturer's Statement of Origin (MSO), the trailer must be weighed and the weight stated and verified by one of the above officials. Trailers under 2,000 lbs. do not require a title, only a tag.
- d) Retention of Titles. All mobile equipment titles are to be applied for and retained by the Office of Maintenance, who shall be charged with their safekeeping.
- e) Non-Conforming Mobile equipment. If the mobile equipment as delivered does not meet specification requirements, the DFM, or designee has the following options, which must be confirmed in writing:
  - Refuse to accept the mobile equipment.
  - Require the vendor to repair or modify the mobile equipment to eliminate the non-conformance.
  - If the non-conformance involves missing features or accessories, the value of which can be readily determined, the item can be accepted, if desired, and the value of the missing items can be deducted from the Procurement Requisition before it is released for payment.
- f) Conforming Mobile equipment. After acceptability is determined, the Shop Superintendent fills in the "Date Received" and "Date Accepted" on the receiving documents and sends it to the DFM for payment process. If the item of mobile equipment in question is assigned to Maintenance, the Maintenance Management System (MMS) Manager at the yard should be notified for inclusion of the item in the MMS inventory. The unit supervisor should also be notified of the arrival of the mobile equipment.
- g) The DFM should retain copies of all pertinent documents for files. The original copy of the procurement requisition is forwarded with the original copies of the invoice to the FDOT District Comptroller's Office for payment.

- h) A copy of the following documents must be sent to the Office of Maintenance Roadway section for tag process:
- Copy of Procurement Requisition
  - Copy of Direct Order
  - Copy of Invoice
  - Copy of Form No. 400-030-02, Request for Purchase of Mobile Equipment (completed by the District)
  - Original Manufacturer's Statement of Origin (MSO)
  - Original Form DHSMV 82040, Application for Certificate of Title With/Without Registration (completed by the dealer)
  - Original Form DHSMV 82042, Vehicle Identification Number and Odometer Verification (if the item is from out of State)
- i) Documents necessary for obtaining tags and titles, as described above, are to be sent by the DFM to the Roadway Section of the Office of Maintenance which will obtain title, registration, and tag. Unless there is an unusual delay at the Department of Highway Safety and Motor Vehicles, this should not require more than 10 working days after receipt of complete, correct documents by the Office of Maintenance. The tag number, when obtained, will become the ME and DOT number.

#### **4.7. SHOP MAINTENANCE AND REPAIR SERVICE RATES**

- 4.7.1.** Purpose – Service rates are a vital tool for analyzing the effectiveness of resources applied to fleet activity. They offer the ability to engage in fleet management best practices such as activity based costing; benchmarking; shop management, repair decision making and analysis of competitiveness with alternative service providers, fleet asset management based on market and economic principals, and life-cycle cost analysis. They also provide a sound method for charging customers or program for shop labor.
- 4.7.2.** Components – Shop labor rate development involves identifying all the direct and indirect costs associated with providing maintenance and repair and computing an amount that will recover these costs when multiplied by the number of units of such good or service consumed by users of the service. Typically, in fleet operations this includes an hour of shop labor, a markup on parts and fuel, and/or fees for ancillary services. The following services shall have rates or fees developed:

1. Maintenance and Repair
2. Parts (acquisition costs and sales)
3. Commercial (management of acquisition and sales)
4. Fleet Administration (costs directly associated with managing and administering the fleet)
5. Fuel Management

**4.7.3.** Application - The shop labor rates will be utilized to calculate the cost of maintenance and repair in FMS, which in turn provides the basis for mobile equipment operating rates detailed in **Chapter 1, Section (11)** of this **Manual**. The shop labor rates shall be reviewed and updated annually.

**4.7.4.** Responsibilities

1. The Office of Maintenance, in concert with the Office of Comptrollers, is responsible for developing the detailed methodology for shop labor rate development, the distribution of specific methodology to the districts, analysis of data compiled, and combining data to develop statewide shop labor rates. They are also responsible for training District Fleet and Accounting personnel in the review and use of the data utilized in shop labor rate calculations.
2. Districts are responsible for accurate and timely development and reporting of data as defined in the shop labor rate development methodology.
3. Districts are required to conduct annual reviews of all staff associated with fleet operations to validate the percentages of time devoted to fleet functions, fleet activities, and the shop labor rate development process.

**4.7.5.** Methodology

- 4.7.5.1 The detailed methodology developed by the Office of Maintenance shall include the following:
- a) Define the services provided by each District in maintenance and fleet administration
  - b) Identify the costs to be recovered
  - c) Allocate costs to cost pools that correspond to the services provided
  - d) Determine billable units of service
  - e) Calculate shop labor rates (Shop/District/Statewide).

The FMS system and State Payroll system shall be utilized to secure direct costs and labor hours. The Department's accounting system and accepted estimating techniques shall be used to determine indirect and overhead costs associated with operating the shops. The Office of Maintenance, in consultation with a team of fleet management and district/central financial staff, will develop a consistent approach to isolating, reporting, and estimating shop related expenses. The goal is to secure costs in a way that accurately reflects the actual costs associated with shop operations, fuel services and fleet administration.

4.7.5.2 Overview and Example:

4.7.5.2.1 **Step 1: Define the services provided by each District maintenance shop**

This step is designed to define the major service functions performed by the District shops. The intent is to develop cost pools that can be recovered through billable units such as labor hours, markups, and fees. Costs that are associated with Maintenance and Repair (M&R), for example, are combined for each shop and then divided by the number of labor hours that can be reasonably expected to be documented on work orders. If the costs of M&R equal \$1,000,000 and there are 10,000 billable hours available, then the shop labor rate is \$100 per hour.

Currently the major services provided in the Districts are:

- a. Maintenance and repair
- b. Parts (acquisition costs and sales)
- c. Commercial (management of acquisition and sales)
- d. Fleet Administration (costs associated with managing and supporting the processes involved with the mobile equipment fleet)
- e. Fuel Management

**4.7.5.2.2 Step 2: Identify Costs to be Recovered**

This step involves creating templates and collecting data of normal budget expenses that generally apply to fleet operations including:

- A listing of every employee that expends time in fleet operations in each district, then securing the time allocations and salary and benefit cost for each of these employees.
- A listing of *non-salary and wage* expenses that generally apply to the operation of a maintenance shop. A sample list is as follows:

<b>Typical Shop Operational <i>Non Salary</i> Expenses</b>	
Binding & Printing	M&R Machine Equipment
Chemicals	M&R Parts Equipment
Clothing Allowance	Mail and Parcel Post
Compliance Testing	Mechanic Tools
Employee Expense Allowance	Membership Dues
Food	Miscellaneous Expenses, Parts Washer Rental
Fuel System Supplies	Motor Fuel and Lubricants, Shop Equipment
General Office Supplies	Other Commodities

**4.7.5.2.3 Step 3: Salary and Benefit Costs to Cost Pools**

The service areas identified in step 1 above each become a “cost pool.” When all of the employees of a District that have duties related to the fleet are accounted for, the percentages of the total time are applied as allocations. The approach used to allocate salary and benefit costs to cost pools is based upon the amount of human resources that are dedicated to each service. That is, if an employee spends 50% of his/her time on maintenance and repair (M&R) and 50% of his/her time acquiring parts, then these percentages are assigned accordingly to the maintenance and repair and parts pools. If the activity is in support of the entire fleet operation (like time spent paying bills, completing Procurement requisitions, etc.), it is assigned to Fleet Administration).

Management time should be assigned to the appropriate cost pool, with management of the repair shop allocated to maintenance, management of the parts department allocated to parts, and general management of the fleet or over the processes involved (such as bill payment) allocated to fleet administration, etc. To accurately determine the percentages of employee time, each

District is asked to complete a survey that identified employees with fleet duties and to assign a percentage of time to each of the four cost pools. A sample of the percentage of time reported for all employees in the Districts is depicted in the following table.

**Table - Fleet Salary and Benefit Allocation to Cost Pools**

Percentage of Time by Category				
DISTRICT	M&R	PARTS	COMMERCIAL	FLEET ADMIN
1	49.7%	11.5%	6.6%	32.3%
2	64.6%	20.0%	0.0%	35.1%
3	65.3%	9.1%	12.5%	13.2%
4	70.0%	0.0%	0.0%	30.0%
5	68.5%	11.8%	0.0%	19.6%
6	66.1%	14.8%	13.2%	6.0%
<b>AVERAGE</b>	<b>64.0%</b>	<b>11.2%</b>	<b>5.4%</b>	<b>22.7%</b>

**4.7.5.2.4 Step 4: Define Shop Labor Rate Structure**

Defining the shop labor rate structure involves the creation of cost models that can be used to allocate the budgetary expenses to each cost pool. Within the model, expenses can be allocated in three ways:

- a. Expenses that are common to all cost pools, such as utilities (electricity, water, sewer, etc.) are allocated based on the percentages of time determined in Step Three above.
- b. Expenses for specific purposes such as mobile equipment parts are allocated directly to the cost pool for which they are used.
- c. Expenses that are shared, but not common to all cost pools, such as employee uniforms that may only apply to M&R and Parts Room, are allocated to those cost pools based on the percentage of use by those pools.

For each District, the expenses reported will be applied to the cost allocation models and total costs by service area calculated. The table on the next page depicts an example of the distribution of all costs in the shop labor rate model.

**Table: Cost Distribution**

<b>District Fleet Shop Salary and Operational Cost Allocation</b>				
<b>District</b>	<b>M&amp;R</b>	<b>Parts</b>	<b>Commercial</b>	<b>FMA</b>
District 1	\$1,233,748	\$273,189	\$156,292	\$769,248
District 2	\$1,793,210	\$5,863	\$0	\$955,107
District 3	\$1,226,078	\$169,766	\$233,884	\$246,979
District 4	\$400,889	\$2,685	\$0	\$167,820
District 5	\$1,824,630	\$310,050	\$0	\$514,534
District 6	\$743,232	\$162,602	\$144,884	\$66,448
<b>Totals</b>	<b>\$7,221,787</b>	<b>\$924,155</b>	<b>\$535,060</b>	<b>\$2,720,137</b>

**4.7.5.2.5 Step 5: Determine Billable Units of Service**

When developing service rates in order to account for the total cost of doing business, it is necessary to determine the units of service that are available to recover the cost associated with the service. For example, M&R costs can be recovered by charging for each hour of a mechanic’s time that is reported on work orders. In the case of mobile equipment parts, the cost of acquiring parts, distributing parts to mechanics, and managing vendor invoices can be recovered through a markup added to the cost of each part.

The table on the next page identifies the methods selected as billable units of service for each cost pool and the associated calculation. These are the methods typically used in the fleet industry.



**Table: Allocation Methods**

<b>Cost Pool</b>	<b>Billable Unit of Service</b>	<b>Rate Calculation</b>
Shop Labor	Direct Mechanic Labor Hours for Maintenance & Repair	Total labor allocation/Total Hours
Parts	% Markup for Each Part	Total parts allocation/Total Parts Expense
Commercial	% Markup for Each Vendor Invoice	Total commercial shop allocation/Total Commercial Expense
Fuel	Fixed cents per gallon markup for each gallon sold	Total fuel Allocation/Total Fuel Expense
Fleet Management & Administration (FMA)	Fixed Monthly cost per Vehicle	Total Fleet Management and Administration Allocation/ Units assigned*12

Once the units of service are defined, the number of billable units for each cost pool is identified based on current available FDOT data in FMS and the payroll system. Examples of the compilations are depicted as follows:

**Direct Labor Hour Calculation (Payroll System Information)**

<u>Hours</u>	<u>Type</u>
2,080	Annual Regular Paid
(402)	Annual Average Leave
<b>1,678</b>	<b>Available at Work</b>
(222)	Break/Training/Misc. Time
<b>1,456</b>	<b>Expected Billable Hours (Reportable Man Hours)</b>

These expected billable hours should be the basis for determining shop labor rates. However, it is essential to ensure that this number of hours is actually billed, and if not, determine where the hours not accounted for are spent. This can be accomplished by comparing the expected hours to the hours actually recorded in FMS. See next table for example.

**Table: Actual vs. Expected Labor Hours**

	Mechanics Allocated	Labor Hours Projected (1456 per Mechanic)	Labor Hours Actual (prior year FMS)
District 1	12.0	17,472	17,791
District 2	17.8	25,917	27,559
District 3	9.2	13,395	10,232
District 4	7.0	10,192	2,996
District 5	15.0	21,840	17,497
District 6	12.0	17,472	5,097
<b>Average Per Mechanic</b>		<b>1,456</b>	<b>1,112</b>

**4.7.5.2.6 Step 6: Calculate shop labor rates**

Utilizing the costs developed and billable units identified in steps one through five above, shop labor rates can be calculated for each category. Example results would be:

District 1 Hourly Rate:	\$70.61
District 3 Hourly Rate:	\$91.53
District 5 Hourly Rate:	\$83.55
<b>Statewide Average Rate:</b>	<b>\$81.90</b>

**Parts Mark Up: 30%**

The preceding is only an example of the type of calculations used to determine shop labor rates. Actual calculations will be performed by the Office of Maintenance.

**4.8 VEHICLE EQUIVALENT UNIT** Purpose –The purpose of Vehicle Equivalent Unit (VEU) values is to reduce fleets that contain a broad range of mobile equipment types into a single value that accurately represents the resource requirements for planning and deployment. To do so, planners determine the annual maintenance requirement in mechanic hours for each class of mobile equipment. Then, by assigning a value of 1 to the maintenance requirement for a common vehicle such as a sedan, planners determine the maintenance hours for other types of vehicles and arrive at a number of equivalencies that can be applied consistently to each vehicle class reviewed. The total number of VEU’s in a fleet determines the staffing requirements for maintenance operations. Additionally, maintenance and repair cost per VEU can be calculated, allowing for cost comparisons across diverse fleets.

- 4.8.2** Example of VEU development: Assume that a fleet has identified that the annual maintenance requirement for a standard sedan is 12 hours and they assigned it a VEU value of 1. They next determined that the average number of annual maintenance hours per vehicle in a class of dump trucks equaled 120 hours. The dump truck takes 10 times more maintenance effort than the sedan (120/12); therefore, the dump truck has a VEU value of 10. If there 100 sedans and 100 dump trucks in this fleet, there would be 1100 total VEU's in the fleet (100 vehicles @ 1 VEU + 100 vehicles @ 10 VEU). Staffing could then be determined based on 1100 hours of maintenance required. The total cost of maintenance could be divided by 1100 to obtain a cost per VEU. This process is commonly used by fleets as a means to assess key resource needs such as staffing size, facility size and throughput, and as a means to compare costs with other fleets.
- 4.8.3** Example of application: Let us assume that in a shop setting, a single mechanic can be expected to produce 1,200 hours of time directly associated with repairs. Using the previous example of determining that a single VEU represents 12 hours of time for a year, the number of VEUs a mechanic can support is 100 (1200 hours/ VEU of 12). Now, if we sum of VEU's for all vehicles in the fleet 1,200 we can estimate that we need 12 mechanics in the shop (1200 VEU's/100 VEUs per mechanic). Further, if we know from experience that each mechanic would require 1.5 average size bays to work efficiently, then we can assume that the shop size would need to be 18 bays or two shifts in a 9 bay facility. Certainly, there are many more applications for the VEU concept, but it should be clear that there is great value in using this methodology in the management of fleet operations.

**APPENDIX CONTENTS:**

Mobile equipment Checklist – All Mobile equipment not requiring a Commercial Driver’s License

Mobile equipment Check list – Mobile equipment requiring a Commercial Driver’s License

Preventive Maintenance Check List – PM “A”, PM “B”, and PM “C” service plans

Illustrations – Pattern for vehicle marking tape

Minimum Mobile Equipment Replacement Criteria

Quality Assurance Review Program

## **Mobile Equipment Checklist** (For mobile equipment not requiring a Commercial Driver's License)

### Daily:

- Interior cleanliness
- Windshield and window cleanliness
- Instruments - all work and readings OK
- Leakage of fluids
- Steering looseness
- Looseness of other linkages as applicable
- Operation of brakes
- Operation of horn
- Operation of pedals and hand controls
- Tire pressure (visual)
- Condition of trailer hitch and wiring (if applicable)
- Cargo security (if applicable)
- Operation of dump bed alarm (if applicable)

### When fueled or weekly, whichever is sooner (in addition to daily checks):

- Operation of all lights

### Weekly (in addition to above daily and when fuel checks):

- First Aid Kit (expiration date)
- Fire Extinguisher (gauge or inspection date)
- Function of wipers and condition of blades
- Function of windshield washers
- Tire condition (damage, adequate tread, and uneven wear)
- Defroster operation
- All controls function
- Coolant, oil, fuel, hydraulic leaks (visual)
- Reflectors (presence, condition)
- Condition of glass
- Condition of mirrors
- Presence and condition of all safety items, such as fire extinguisher and first aid kit

For mobile equipment requiring a Commercial Driver's License use **Form No. 400-000-13, Commercial Vehicle Pre-Trip Inspection** (Link: <https://fms.fdot.gov/Anonymous/SendDocumentToClient?documentId=1852> )

**AUTOMOTIVE AND TRUCKING EQUIPMENT THROUGH ONE TON  
OILS, FLUIDS, FILTERS – MUST MEET OR EXCEED OEM SPECIFICATIONS**

A Service - 5 Months/5,000 Miles

Vehicle No. \_\_\_\_\_ Mileage \_\_\_\_\_ Date \_\_\_\_\_

Place (✓) in blocks that are satisfactory. Place (X) in blocks that are unsatisfactory. Place (N/A) in blocks that do not apply.

- INSIDE 1. \_\_\_ INSTRUMENTS AND CONTROLS – Check all instruments, gauges, switches, controls and warning devices.
- VEHICLE 2. \_\_\_ LIGHTS AND HORN – Inspect all lights, signals.
- CHECKS 3. \_\_\_ SEAT BELTS – Check fabric and buckles.
4. \_\_\_ BRAKE AND CLUTCH – Test to determine if both function properly, check pedal free travel.
- OUTSIDE 5. \_\_\_ GLASS – Check for damage/accident.
- VEHICLE 6. \_\_\_ BODY CONDITION – Rust/damage that will affect operation.
- CHECKS 7. \_\_\_ WINDSHIELD WIPERS AND BLADE – Check for serviceability.
8. \_\_\_ LIGHT LENSES – REFLECTORS – Broken or damaged.
- UNDER 9. \_\_\_ STEERING AND SUSPENSION – Check for free play.
- VEHICLE 10. \_\_\_ LEAKS – Visually inspect the engine compartment, gear housings, backing plates, for water, fluid, oil or oil leaks.
- CHECKS 11. \_\_\_ EXHAUST SYSTEM – Inspect muffler, exhaust and tail pipe and all connections for leaks.
12. \_\_\_ SHOCK ABSORBERS – Check for looseness.
13. \_\_\_ DRIVE LINE UNITS – Engine mounts, transmission mounts, transfer case mounts, PTO mounting, clutch housing, drive shafts, U-joints, differential(s).
14. \_\_\_ WHEELS AND TIRES – Wheel lugs for tightness, tires for damage and wear, rotate if required by wear, check air pressure.
- LUBRICATE 15. \_\_\_ CHASSIS – Service all fittings, oil all control linkage.
16. \_\_\_ BODY – Lubricate all door and deck hinges, Striker plates and latches.
17. \_\_\_ HEAT CONTROL VALVE – Oil check operation.
- SERVICE/ 18. \_\_\_ ENGINE – Change oil and oil filter. \_\_\_\_\_ Qts.
- CHANGE
- CHECK/ADD 19. \_\_\_ TRANSMISSION MANUAL – Check fluid level \_\_\_\_\_ Pts.
- FLUID 20. \_\_\_ GEAR HOUSINGS – Check fluid level \_\_\_\_\_ Pts.
21. \_\_\_ DIFFERENTIAL(S) – Check fluid level.
- UNDER HOOD 22. \_\_\_ WINDSHIELD WASHER – Check water level.
- CHECKS 23. \_\_\_ AIR CLEANER – Remove and clean.
24. \_\_\_ BATTERY – Check fluid level, cables and terminals.
25. \_\_\_ HOSES AND DRIVE BELTS – Check serviceability and tension.
26. \_\_\_ COMPRESSOR/AIR CONDITIONER – Run unit, observe Freon level at sight port.
27. \_\_\_ RADIATOR – Check coolant level.
- CHECK/ADD 28. \_\_\_ BRAKE MASTER CYLINDER – Check fluid level.
- FLUID 29. \_\_\_ POWER STEERING – Check fluid level.
30. \_\_\_ TRANSMISSION/AUTOMATIC – Check fluid level \_\_\_\_\_ Qts.
- INSIDE VEH. 31. \_\_\_ Replace PM service indicator in folder.

NOTE: Some items applicable only on certain vehicles. Use this guide along with the Manufacturer's maintenance manual to prevent missing recommended service requirements which would void the Manufacturer's vehicle warranties.

\_\_\_\_\_  
Shop Supervisor's Signature

\_\_\_\_\_  
Mechanic's Signature

**AUTOMOTIVE AND TRUCKING EQUIPEMENT THROUGH ONE TON  
OILS, FLUIDS, FILTERS – MUST MEET OR EXCEED OEM SPECIFICATIONS**

B Service - 15 Months/15,000 Miles

- Vehicle No. \_\_\_\_\_ Mileage \_\_\_\_\_ Date \_\_\_\_\_  
Place (✓) in blocks that are satisfactory. Place (X) in blocks that are unsatisfactory. Place (N/A) in blocks that do not apply.
- INSIDE 1. \_\_\_ INSTRUMENTS AND CONTROLS – Check all instruments, gauges, switches, controls and warning devices.
- VEHICLE 2. \_\_\_ LIGHTS AND HORNS – Inspect all lights, signals.  
CHECKS 3. \_\_\_ SEAT BELTS – Check fabric and buckles.  
4. \_\_\_ BRAKE AND CLUTCH – Test to determine if both function properly, check pedal free travel.
- OUTSIDE 5. \_\_\_ GLASS – Check for damage/accident.  
VEHICLE 6. \_\_\_ BODY CONDITION – Rust/damage that will affect operation, check body and door drain holes.  
CHECKS 7. \_\_\_ WINDSHIELD WIPERS AND BLADES – check for serviceability.  
8. \_\_\_ LIGH LENSES/REFLECTORS – Broken or damaged.  
9. \_\_\_ STATE SAFETY INSPECCTION – Complete.
- UNDER 10. \_\_\_ STEERING AND SUSPENSION – Check for free play.  
VEHICLE 11. \_\_\_ LEAKS – Visually inspect the engine compartment, gear housings, backing plates, for water, fluid oil or fuel leaks.  
CHECKS 12. \_\_\_ EXHAUST SYSTEM – Inspect muffler, exhaust and tail pipe and all connections for leaks.  
13. \_\_\_ SHOCK ABSORBERS – Check for looseness and condition.  
14. \_\_\_ DRIVE LINE UNITS – Engine mounts, transmission mounts, transfer case mounts, PTO mounting, clutch housing, Drive shafts, U-joints, differential(s).  
15. \_\_\_ WHEELS AND TIRES – Wheel lugs for tightness, tires for damage and wear, rotate if required by wear, check air pressure.
- LUBRICATE 16. \_\_\_ CHASSIS – Service all fittings, oil all control linkage.  
17. \_\_\_ BODY – Lubricate all door and deck hinges, striker plates and latches, door lock cylinders.  
18. \_\_\_ HEAT CONTROL VALVVE – Oil, check operation.  
19. \_\_\_ FREE RUNNING HUBS – Clean and repack if operated in water.
- SERVICE/  
CHANGE 20. \_\_\_ ENGINE – Change oil and oil filter \_\_\_\_\_ Qts.  
CHECK/ADD 21. \_\_\_ TRANSMISSION MANUAL – Check fluid level \_\_\_\_\_ Pts.  
FLUID 22. \_\_\_ GEAR HOUSINGS – Check fluid level \_\_\_\_\_ Pts.  
23. \_\_\_ DIFFERENTIAL(S) – Check fluid level, change if operated in water \_\_\_\_\_ Pts.
- UNDER 24. \_\_\_ WINDSHIELD WASHER – Check water level.  
HOOD 25. \_\_\_ FUEL FILTER – Clean, replace filter element.  
CHECKS 26. \_\_\_ EMMISSION CONTROL SYSTEM – Replace PCV valve, replace vapor storage filter element, service system.  
27. \_\_\_ AIR CLEANER OIL BATH – Clean and replace oil \_\_\_\_\_ Qts.  
28. \_\_\_ AIR CLEANER DRY – Replace element.  
29. \_\_\_ BATTERY – Check fluid level, cables and terminals.  
30. \_\_\_ HOSES AND DRIVE BELTS – Check serviceability and tension.  
31. \_\_\_ COMPRESSOR AIR CONDITIONER – Run unit, observe Freon level at sigh port.  
32. \_\_\_ ENGINE TUNE-UP – Replace plugs, points, check timing and RPM.  
33. \_\_\_ ELECTRICAL TEST – Charging and starting circuits will be load tested.  
34. \_\_\_ RADIATOR – Check level, check with hydrometer, and add rust inhibitors.
- CHECK/ADD 35. \_\_\_ BRAKE MASTER CYLINDER – Check fluid level.  
FLUID 36. \_\_\_ POWER STEERING – Check fluid level.  
37. \_\_\_ TRANSMISSION AUTOMATIC – Check fluid level \_\_\_\_\_ Pts.
- INSIDE VEH. 38. \_\_\_ Replace PM Service indicator in holder.

NOTE: Some items applicable only on certain vehicles. Use this guide along with the Manufacturer's maintenance manual to prevent missing recommended service requirements which would void the Manufacturer's vehicle warranties.

\_\_\_\_\_  
Shop Supervisor's Signature

\_\_\_\_\_  
Mechanic's Signature

**AUTOMOTIVE AND TRUCKING EQUIPMENT THROUGH ONE TON  
 OILS, FLUIDS, FILTERS – MUST MEET OR EXCEED OEM SPECIFICATIONS**

C Service - 30 Months/30,000 Miles

Vehicle No. \_\_\_\_\_ Mileage \_\_\_\_\_ Date \_\_\_\_\_

Place (✓) in blocks that are satisfactory. Place (X) in blocks that are unsatisfactory. Place (N/A) in blocks that do not apply.

- |                             |   |
|-----------------------------|---|
| INSIDE                      | 1. <input type="checkbox"/> INSTRUMENTS AND CONTROLS – Check all instruments, gauges, switches, controls and warning devices.   |
| VEHICLE CHECKS              | 2. <input type="checkbox"/> LIGHTS AND HORN – Inspect all lights, signals.<br>3. <input type="checkbox"/> SEAT BELTS – Check fabric and buckles.<br>4. <input type="checkbox"/> BRAKE AND CLUTCH – Test to determine if both function properly, check pedal free travel.  |
| OUTSIDE VEHICLE CHECKS      | 5. <input type="checkbox"/> GLASS – Check for damage/accident.<br>6. <input type="checkbox"/> BODY CONDITION – Rust/damage that will affect operation, check body and door drain holes.<br>7. <input type="checkbox"/> WINDSHIELD WIPERS AND BLADES – Check for serviceability.<br>8. <input type="checkbox"/> LIGHT LENSES/REFLECTORS – Broken or damaged.<br>9. <input type="checkbox"/> BRAKES – Inspect front drums and linings for wear and damage, backing plate for tightness, repack wheel bearings.  |
| UNDER VEHICLE CHECKS        | 10. <input type="checkbox"/> STATE SAFETY INSPECTION – Complete<br>11. <input type="checkbox"/> STEERING AND SUSPENSION – Check for free play.<br>12. <input type="checkbox"/> LEAKS – Visually inspect the engine compartment, gear housings, backing plates for water, fluid oil or fuel leaks.   |
| LUBRICATE                   | 13. <input type="checkbox"/> EXHAUST SYSTEM – Inspect muffler, exhaust and tail pipe and all connections for leaks.<br>14. <input type="checkbox"/> SHOCK ABSORBERS – Check for looseness and condition.<br>15. <input type="checkbox"/> DRIVE LINE UNITS – Engine mounts, transmission mounts, transfer case mounts, PTO mounting, clutch housing, Drive shafts, U-joints, differential(s).<br>16. <input type="checkbox"/> WHEELS AND TIRES – check wheel lugs for tightness, tires for damage and wear, rotate if required by wear, Check air pressure.  |
| SERVICE/ CHANGE             | 17. <input type="checkbox"/> CHASSIS – Service all fittings, oil all control linkage, lubricate sealed plug fittings.<br>18. <input type="checkbox"/> BODY – Lubricate all door and deck hinges, striker plates and latches, door lock cylinders.<br>19. <input type="checkbox"/> HEAT CONTROL VALVE – Oil, check operation.<br>20. <input type="checkbox"/> FREE RUNNING HUBS – Clean and repack.  |
| CHECK/ADD FLUID             | 21. <input type="checkbox"/> ENGINE – Change oil and oil filter _____ Qts.<br>22. <input type="checkbox"/> TRANSMISSION MANUAL – Change fluid _____ Qts.<br>23. <input type="checkbox"/> TRANSFER CASE – Change fluid _____ Qts.<br>24. <input type="checkbox"/> DIFFERENTIAL(S) – Change fluid _____ Qts.<br>25. <input type="checkbox"/> TRANSMISSION AUTOMATIC – Adjust bands, change fluid and filter _____ Qts.  |
| UNDER HOOD CHECKS           | 26. <input type="checkbox"/> TRANSMISSION MANUAL – Check fluid level _____ Pts.<br>27. <input type="checkbox"/> GEAR HOUSINGS – Check fluid level _____ Pts.<br>28. <input type="checkbox"/> DIFFERENTIAL – Check fluid level _____ Pts.<br>29. <input type="checkbox"/> WINDSHIELD WASHER – Check water level.<br>30. <input type="checkbox"/> FUEL FILTER – Clean, replace filter element.<br>31. <input type="checkbox"/> EMISSION CONTROL SYSTEM – Replace PCV valve, replace vapor storage filter element, service system.   |
| CHECK/ADD FLUID INSIDE VEH. | 32. <input type="checkbox"/> AIR CLEANER OIL BATH – Clean and replace oil _____ Qts.<br>33. <input type="checkbox"/> AIR CLEANER DRY – Replace element.<br>34. <input type="checkbox"/> BATTERY – Check fluid level, cables and terminals.<br>35. <input type="checkbox"/> HOSES AND DRIVER BELTS – Replace.<br>36. <input type="checkbox"/> COMPRESSOR AIR CONDITION – Run unit, observe Freon level at sight port.<br>37. <input type="checkbox"/> ENGINE TUNE UP – Replace plugs, points check timing and RPM.<br>38. <input type="checkbox"/> ELECTRICAL TEST – Charging and starting circuits will be load tested.<br>39. <input type="checkbox"/> RADIATOR – Drain, flush and recharge _____ Qts. |
|                             | 40. <input type="checkbox"/> BRAKE MASTER CYLINDER – Check fluid level.<br>41. <input type="checkbox"/> POWER STEERING – Check fluid level.<br>42. <input type="checkbox"/> Replace PM Service indicator in holder.   |

NOTE: Some items applicable only on certain vehicles. Use this guide along with the Manufacturer's maintenance manual to prevent missing recommended service requirements which would void the Manufacturer's vehicle warranties.

\_\_\_\_\_  
 Shop Supervisor's Signature

\_\_\_\_\_  
 Mechanic's Signature



**TRUCKING EQUIPMENT ABOVE ONE TON  
SIGN TRUCKS, BUCKET TRUCK, POST DRIVER, HERBICIDE UNIT  
OILS, FLUIDS, FILTERS – MUST MEET OR EXCEED OEM SPECIFICATIONS**

A Service CHASSIS/CAB ONLY

Vehicle No. \_\_\_\_\_ Mileage \_\_\_\_\_ Hours \_\_\_\_\_ Date \_\_\_\_\_

Place (✓) in blocks that are satisfactory. Place (X) in blocks that are unsatisfactory. Place (N/A) in blocks that do not apply.

1.  INSTRUMENTS AND CONTROLS – Check all instruments, gauges, switches, controls and warning devices.
2.  HORN – Inspect and check for proper operation. Air and electric.
3.  SEAT BELTS – Check fabric and buckles.
4.  BRAKE AND CLUTCH – Test to determine if both function properly, check pedal free travel. Test parking brake
5.  GLASS and MIRRORS – Check for operation and service/ability.
6.  CHASSIS/CAB – Rust/Accident damage, check mud flaps.
7.  WINDSHIELD WIPERS AND WASHERS – check for service/ability.
8.  LIGHTS, LENSES/REFLECTORS – Inspect all lights and signals, broken or damaged lenses.  
Replace bulbs as needed.
9.  TRAILER CONNECTIONS – Check condition of electrical cords, air hoses, and hitch condition.
10.  STEERING AND SUSPENSION – Check for free play, looseness, wear, cracked springs,  
Check wheel – bearing adjustment.
11.  LEAKS – Visually inspect engine compartment, gear cases, backing plates, hub seals,  
Fuel tanks for indication of leaking.
12.  EXHAUST SYSTEM – Inspect muffler, exhaust and tail pipe and all connections for leaks.
13.  DRIVELINE UNIT – Check engine, transmission, differential mounts, drive shaft yokes,  
u-joints, and center bearings.
14.  WHEELS AND TIRES – Wheel lugs for tightness, tires for damage and wear,  
Adjust air pressure, replace missing valve caps.
15.  FRAME – Check for cracks, loose bolts, and rivets.
16.  VACANT
17.  CHASSIS/CAB – Service all fittings, oil all control linkage, lubricate per OEM specifications.
18.  ENGINE – CHANGE OIL & FILTER \_\_\_\_\_ qts. OIL # \_\_\_\_\_. Filter # \_\_\_\_\_.
19.  AIR CLEANER – Wet type, clean and change oil \_\_\_\_\_ pts. Dry type check restriction gauge,  
Clean element.
20.  AIR COMPRESSOR – Clean air intake, check mounting bolts and hoses, check filter.
21.  BRAKE/CLUTCH/MASTER CYLINDER – Check and adjust fluid level.
22.  DIFFERENTIAL(S) – Check and adjust fluid level, clean breathers \_\_\_\_\_ pts. Fluid # \_\_\_\_\_.
23.  TRANSMISSION, TRANSFER CASE – Adjust fluid level \_\_\_\_\_ pts. Fluid # \_\_\_\_\_.
24.  POWER STEERING – Check and adjust fluid level \_\_\_\_\_ pts. Fluid # \_\_\_\_\_.
25.  TWO SPEED AXLE SHIFT UNIT – Check and adjust fluid level \_\_\_\_\_ pts. Check operation.
26.  WINDSHIELD WASHER – Check solvent level and top off.
27.  FUEL FILTER – REPLACE FILTERS # \_\_\_\_\_.
28.  DRIVE BELTS AND HOSES – Check tension and serviceability. Adjust belts if needed.
29.  COOLING SYSTEM – Adjust coolant level, adjust coolant temp, protected (-20 to -40) \_\_\_\_\_ degrees Coolant # \_\_\_\_\_.
30.  Test conditioner concentration and adjust, DCA \_\_\_\_\_.
31.  BATTERY – Check condition, cables, and terminals, clean if needed.
32.  WIRING AND CONNECTIONS – Check for cracked and bare wiring.
33.  AIR CONDITIONER/HEATER – Check operation.
34.  BRAKES – Check pads and shoe condition and record % left. ADJUST BRAKES PER OEM SPECIFICATION.
35.  AIR DRYER/TANKS – Check air drier operation, purge valve operation, drain air tanks, test for moisture.
36.  SAFETY EQUIP – Check backup alarm.
37.  A. REPLACE P/M SERVICE STICKER. ADD 5 MONTHS, 5000 MILES.  
B. REPLACE PM SERVICE STICKER. ADD 5 MONTHS, 200 HRS. SEWER CLEANER ONLY.

\*STROBES, FLASHTUBES, ARROWBOARD, BULBS NOT INCLUDED.

NOTE: Some items applicable only on certain vehicles. Use this guide along with the Manufacturer's maintenance manual to prevent missing recommended service requirements which would void the Manufacturer's vehicle warranties.

\_\_\_\_\_  
Shop Supervisor's Signature

\_\_\_\_\_  
Mechanic's Signature

**TRUCKING EQUIPMENT ABOVE ONE TON  
SIGN TRUCKS, BUCKET TRUCK, POST DRIVERS, HERBICIDE UNIT  
OILS, FLUIDS, FILTERS – MUST MEET OR EXCEED OEM SPECIFICATIONS**

C Service CHASSIS/CAB ONLY

Vehicle No. \_\_\_\_\_ Mileage \_\_\_\_\_ Hours \_\_\_\_\_ Date \_\_\_\_\_

Place (√) in blocks that are satisfactory. Place (X) in blocks that are unsatisfactory. Place (N/A) in blocks that do not apply.

1.  INSTRUMENTS AND CONTROLS – Check all instruments, gauges, switches, controls and warning devices.
2.  HORN – Inspect and check for proper operation, air and electric.
3.  SEAT BELTS – Check fabric and buckles.
4.  BRAKE AND CLUTCH – Test to determine if both function properly, check pedal free travel. Test parking brake.
5.  GLASS AND MIRRORS – Check for operation and service/ability.
6.  CHASSIS/CAB – Rust/accident, damage. Check mud flaps.
7.  WINDSHIELD WIPERS AND WASHERS – Check service/ability.
8.  LIGHTS, LENSES/REFLECTORS – Inspect all lights and signals, broken or damaged lenses. Replace as needed.
9.  TRAILER CONNECTIONS – Check condition of electrical cords, air hoses, and hitch condition.
10.  STEERING AND SUSPENSION – Check for free play, looseness, wear, cracked springs, pack wheel bearings.
11.  LEAKS – Visually inspect engine compartment, gear cases, backing plates, hub seals, Fuel tanks for indication of leaking.
12.  EXHAUST SYSTEM – Inspect muffler, exhaust and tail pipe and all connections for leaks.
13.  DRIVELINE UNITS – Check engine, transmission, differential mounts, drive shaft yokes u-joints, center bearings.
14.  WHEELS AND TIRES – Wheel lugs for tightness, tires for damage and wear, adjust air pressure, and replace missing valve caps.
15.  FRAME – Check for cracks, loose bolts and rivets.
16.  VACANT
17.  CHASSIS CAB – Lube all fittings, oil all control linkage, lubricate per OEM specifications.
18.  ENGINE – CHANGE OIL & FILTERS \_\_\_\_\_ qts oil. Filter # \_\_\_\_\_.
19.  AIR CLEANER – Wet type, clean and change oil \_\_\_\_\_ pts. Dry type CHANGE ELEMENT # \_\_\_\_\_.
20.  AIR COMPRESSOR – Check mounting bolts and hoses, CHANGE FILTER ELEMENT # \_\_\_\_\_.
21.  BRAKE/CLUTCH MASTER CYLINDER – Check and adjust fluid level.
22.  DIFFERENTIAL(S) – CHANGE FLUID \_\_\_\_\_ pts. FLUID # \_\_\_\_\_.
23.  TRANSMISSION, TRANSFER CASE, CHANGE FLUID & FILTERS, Fluid # \_\_\_\_\_, Filter # \_\_\_\_\_.
24.  POWER STEERING – Check and adjust fluid level \_\_\_\_\_ pts. Fluid # \_\_\_\_\_.
25.  TWO SPEED AXLE SHIFT UNIT – Check and adjust fluid level \_\_\_\_\_ pts. Check operation.
26.  WINDSHIELD WASHER – Check solvent level and top off.
27.  FUEL FILTER – CHANGE FILTERS \_\_\_\_\_.
28.  DRIVE BELTS AND HOSES- Check tension and service/ability. Adjust belts if needed.
29.  COOLING SYSTEM, CHANGE COOLANT & FILTER. Adjust temperature protected to (-20 to -40) \_\_\_\_\_ degrees/
30.  BATTERY – Check condition, cables, and terminals, clean if needed.
31.  WIRING AND CONNECTIONS – Check for cracked and bare wiring.
32.  AIR CONDITIONER/HEATER – Check operation.
33.  BRAKES – Check pads, shoe and drum condition, and record % left \_\_\_\_%. ADJUST BRAKES PER OEM SPEC.
34.  AIR DRIER/TANKS – CHANGE DESSICANT CARTRIDGE # \_\_\_\_\_. Check purge valve operation. Drain tanks.
35.  SAFETY EQUIPMENT – Check backup alarm.
36.  A. REPLACE P/M SERVICE STICKER, ADD 5 MONTHS, 5000 MILES.  
 B. REPLACE PM SERVICE STICKER; ADD 5 MONTHS, 200 HRS. SEWER CLEANER ONLY.

\*STROBES, FLASHTUBES, ARROWBOARD, BULBS NOT INCLUDED.

NOTE: Some items applicable only on certain vehicles. Use this guide along with the Manufacturer's maintenance manual to prevent missing recommended service requirements which would void the Manufacturer's vehicle warranties.

\_\_\_\_\_  
Shop Supervisor's Signature

\_\_\_\_\_  
Mechanic's Signature

**MOWERS, RIDING MOWERS, TOWED MOWERS, LIFT TYPE MOWERS  
OILS, FLUIDS, FILTERS – MUST MEET OR EXCEED OEM SPECIFICATIONS**

A Service

Vehicle No. \_\_\_\_\_ Hours \_\_\_\_\_ Date \_\_\_\_\_

Place (√) in blocks that are satisfactory. Place (X) in blocks that are unsatisfactory. Place (N/A) in blocks that do not apply.

1 – 13 complete for all mowers, 14 – 24 complete for engine powered only.

1. \_\_\_ SHIELDING – Check condition and mounting.
2. \_\_\_ HEIGHT CRANK – Check condition and operation.
3. \_\_\_ WHEELS AND TIRES – Check condition, check air pressures, check bearing adjustment.
4. \_\_\_ FRAME – Check bent, broken or twisted frame.
5. \_\_\_ GEAR BOXES – Adjust oil level \_\_\_\_\_ pts.
6. \_\_\_ DRIVE SHAFTS, SLIP JOINTS, U-JOINTS – Check condition.
7. \_\_\_ DRIVE BELTS – Check and adjust tension and condition.
8. \_\_\_ SLIP CLUTCHES – Check condition and operation.
9. \_\_\_ HYDRAULIC CYLINDERS – Check leaks, ram condition, mounts, hoses and lines.
10. \_\_\_ PULLYS, IDLERS – Check condition and mountings.
11. \_\_\_ CUTTING EDGES – Check condition of blades/knives.
12. \_\_\_ REELS, ROTORS, CUTTER BARS – Check condition and operation.
13. \_\_\_ LUBRICATE – Service all fittings, oil or grease all contact points, oil all linkage and pivots. Per OEM spec.
14. \_\_\_ INSTRUMENTS AND CONTROLS – Check gauges, switches, controls and warning devices.
15. \_\_\_ ENGINE CHANGE OIL AND FILTERS - \_\_\_\_\_ qts. Oil # \_\_\_\_\_ Filter # \_\_\_\_\_
16. \_\_\_ AIR BREATHER – CHANGE AIR FILTER ELEMENT # \_\_\_\_\_
17. \_\_\_ FUEL SYSTEM – Drain tank sediment. CHANGE FILTERS # \_\_\_\_\_
18. \_\_\_ LIGHTS – Check all lights, reflectors, wiring and receptacles. Replace bulbs as necessary.
19. \_\_\_ LANDING GEAR – Check pads, wheels, gear boxes, legs, mounting bolts, broken welds, ratchets and operation.
20. \_\_\_ SAFETY DEVICES – Check all safety devices for proper operation and interlocks.
21. \_\_\_ BRAKES - Test operation, check condition and adjust if needed.
22. \_\_\_ COOLING SYSTEM – Adjust coolant level & temp. Protected to, (-20 to -40). \_\_\_ degrees, Coolant # \_\_\_\_.
23. \_\_\_ HITCH – Check hitch condition, safety chains.
24. \_\_\_ REPLACE P/M SERVICE STICKER, ADD 5 MONTHS AND 200 HRS.

\*STROBES, FLASHTUBES ARROWBOARD BULBS NOT INCLUDED

NOTE: Some items applicable only on certain vehicles. Use this guide along with the Manufacturer's maintenance manual to prevent missing recommended service requirements which would void the Manufacturer's equipment warranties.

\_\_\_\_\_  
Shop Supervisor's Signature  
Mowers A

\_\_\_\_\_  
Mechanic's Signature

**MOWERS, RIDING MOWERS, TOWED MOWERS, LIFT TYPE MOWERS  
OILS, FLUIDS, FILTERS – MUST MEET OR EXCEED OEM SPECIFICATIONS**

C Service

Vehicle No. \_\_\_\_\_ Hours \_\_\_\_\_ Date \_\_\_\_\_

Place (√) in blocks that are satisfactory. Place (X) in blocks that are unsatisfactory. Place (N/A) in blocks that do not apply.

1 – 13 complete for all mowers, 14 – 24 complete for engine powered only.

1. \_\_\_ SHIELDING – Check condition and mounting.
2. \_\_\_ HEIGHT CRANK – Check condition and operation.
3. \_\_\_ WHEELS AND TIRES – Check condition, check air pressures, check bearing adjustment.
4. \_\_\_ FRAME – Check bent, broken or twisted frame.
5. \_\_\_ GEAR BOXES – Adjust oil level \_\_\_\_\_ pts.
6. \_\_\_ DRIVE SHAFTS, SLIP JOINTS, U-JOINTS – Check condition.
7. \_\_\_ DRIVE BELTS – Check and adjust tension and condition.
8. \_\_\_ SLIP CLUTCHES – Check condition and operation.
9. \_\_\_ HYDRAULIC CYLINDERS – Check leaks, ram condition, mounts, hoses and lines.
10. \_\_\_ PULLYS, IDLERS – Check condition and mountings.
11. \_\_\_ CUTTING EDGES – Check condition of blades/knives.
12. \_\_\_ REELS, ROTORS, CUTTER BARS – Check condition and operation.
13. \_\_\_ LUBRICATE – Service all fittings, oil or grease all contact points, oil all linkage and pivots. Per OEM spec.
14. \_\_\_ INSTRUMENTS AND CONTROLS – Check gauges, switches, controls and warning devices.
15. \_\_\_ ENGINE CHANGE OIL AND FILTERS - \_\_\_\_\_ qts. Oil # \_\_\_\_\_ Filter # \_\_\_\_\_
16. \_\_\_ AIR BREATHER – CHANGE AIR FILTER ELEMENT # \_\_\_\_\_
17. \_\_\_ FUEL SYSTEM – Drain tank sediment. CHANGE FILTERS # \_\_\_\_\_
18. \_\_\_ LIGHTS – Check all lights, reflectors, wiring and receptacles. Replace bulbs as necessary.
19. \_\_\_ LANDING GEAR – Check pads, wheels, gear boxes, legs, mounting bolts, broken welds, ratchets and operation.
20. \_\_\_ SAFETY DEVICES – Check all safety devices for proper operation and interlocks.
21. \_\_\_ BRAKES - Test operation, check condition and adjust if needed.
22. \_\_\_ COOLING SYSTEM – CHANGE COOLANT AND FILTER \_\_\_\_\_ pts. Coolant # \_\_\_\_\_  
Adjust temperature protected to (-20 to -40) \_\_\_\_\_ degrees.
23. \_\_\_ HITCH – Check hitch condition, safety chains.
24. \_\_\_ REPLACE P/M SERVICE STICKER, ADD 5 MONTHS AND 200 HRS.

\*STROBES, FLASHTUBES ARROWBOARD BULBS NOT INCLUDED

NOTE: Some items applicable only on certain vehicles. Use this guide along with the Manufacturer's maintenance manual to prevent missing recommended service requirements which would void the Manufacturer's equipment warranties.

\_\_\_\_\_  
Shop Supervisor's Signature

\_\_\_\_\_  
Mechanic's Signature

**TOWED EQUIPMENT**  
**WOOD CHIPPERS, CONCRETE MIXERS, WELDER, AIR COMPRESSOR**  
**ARROW & MESSAGE BOARDS, WATER PUMP, SEEDED/ROLLER**  
**OILS, FLUIDS, FILTERS – MUST MEET OR EXCEED OEM SPECIFICATIONS**

A Service

Vehicle No. \_\_\_\_\_ Hours \_\_\_\_\_ Date \_\_\_\_\_

Place (√) in blocks that are satisfactory. Place (X) in blocks that are unsatisfactory. Place (N/A) in blocks that do not apply.

1.  INSTRUMENTS AND CONTROLS – Check gauges, switches, controls and warning devices.
2.  SHIELDING – Check condition and mounting.
3.  HEIGHT ADJUSTER – Check condition and operation.
4.  WHEELS AND TIRES – Check condition, wear, adjust air pressure, check wheel bearing adjustment.
5.  FRAME/DECK/BODY – Check condition.
6.  GEAR BOXES – Check vents/breathers/mounting. Adjust oil level \_\_\_\_\_ pts. Oil# \_\_\_\_\_.
7.  DRIVE SHAFTS, U-JOINTS – Check condition.
8.  DRIVE BELTS – Check condition, adjust as needed.
9.  SLIP CLUTCHES – Check condition and operation. Adjust if needed.
10.  HYDRAULIC SYSTEM – Check for leaks, ram condition, mounts, hoses/lines, pump, cylinders, valves  
Adjust oil level \_\_\_\_\_ pts. Oil # \_\_\_\_\_.
11.  PULLEYS/IDLERS – Check condition and mountings.
12.  CUTTING EDGES – Check condition of blades, knives.
13.  REELS, ROTORS, CUTTER BARS – Check condition and operation.
14.  LUBRICATE – Lube all fittings, oil or grease all contact points, oil all linkage and pivots, per OEM spec.
15.  ENGINE – CHANGE OIL & FILTERS \_\_\_\_\_ qts. Oil # \_\_\_\_\_ Filter # \_\_\_\_\_.
16.  AIR CLEANER – Oil type, service \_\_\_\_\_ pts. Dry type check and clean. Check restriction gauge.
17.  FUEL SYSTEM – Drain tank sediment. CHANGE FILTERS # \_\_\_\_\_.
18.  COMPRESSOR – Adjust oil level \_\_\_\_\_ pts. Oil # \_\_\_\_\_. Drain condensate from oil reservoir.
19.  EXHAUST SYSTEM – Check muffler and connections for leaks.
20.  BATTERIES – Adjust electrolyte level. Check cables, connections.
21.  LIGHTS- Check all lights, reflectors, wiring and receptacles. \*Replace bulbs as necessary.
22.  STABILIZERS – Check condition, operation and lubricate.
23.  SAFETY DEVICES – Check all safety equipment.
24.  BRAKES – Check pads, shoes and drum condition. ADJUST BRAKES PER OEM SPEC.
25.  BRAKES HYDRAULIC – Check and adjust fluid level. Test operation.
26.  BRAKES ELECTRIC – Test operation, wiring and connections, operation of BREAKAWAY DEVICE.
27.  COOLING SYSTEM. – Adjust coolant level & temp. Protected to (-20 to -40) \_\_\_\_\_ degrees. Test conditioner concentration & adjust, DCA \_\_\_\_\_. Coolant# \_\_\_\_\_.
28.  RADIATOR/FAN – Check water pump, fan. Check radiator fins & air intake screens for restrictions.
29.  HITCH- Check hitch and safety chains.
30.  REPLACE P/M SERVICE STICKER, ADD 5 MONTHS AND 200 HOURS.

\*STROBES, FLASHTUBES, ARROWBOARD BULBS NOT INCLUDED

NOTE: Some items applicable only on certain vehicles. Use this guide along with the Manufacturer's maintenance manual to prevent missing recommended service requirements which would void the Manufacturer's equipment warranties.

\_\_\_\_\_  
Shop Supervisor's Signature  
Towed Equip A

\_\_\_\_\_  
Mechanic's Signature

**TOWED EQUIPMENT**  
**WOOD CHIPPERS, CONCRETE MIXERS, WELDER,**  
**AIR COMPRESSOR, ARROW & MESSAGE BOARDS, WATER PUMPS.**  
**OILS, FLUIDS, FILTERS – MUST MEET OR EXCEED OEM SPECIFICATIONS**

C Service

Vehicle No. \_\_\_\_\_ Hours \_\_\_\_\_ Date \_\_\_\_\_

Place (√) in blocks that are satisfactory. Place (X) in blocks that are unsatisfactory. Place (N/A) in blocks that do not apply.

1. \_\_\_ INSTRUMENTS/CONTROLS – Check gauges, switches, controls and warning devices.
2. \_\_\_ SHEILDING – Check condition and mounting.
3. \_\_\_ HEIGHT ADJUSTER – Check condition and operation, lube.
4. \_\_\_ WHEELS AND TIRES – Check condition, check air pressure, check bearing adjustment.
5. \_\_\_ FRAME/DECK/BODY – Check bent, broken or twisted frame, rust damage.
6. \_\_\_ GEAR BOXES – Clean vents and breathers, check mountings.
7. \_\_\_ DRIVE SHAFTS/U-JOINTS – Check condition.
8. \_\_\_ DRIVE BELTS – Check condition, adjust as needed.
9. \_\_\_ SLIP CLUTCHES – Check condition and operation.
10. \_\_\_ HYDRAULIC SYSTEM – Check leaks, ram condition, mounts, hoses/lines, pumps, cylinders, valves.  
CHANGE OIL & FILTERS \_\_\_\_\_ qts. Oil # \_\_\_\_\_ Filter # \_\_\_\_\_.
11. \_\_\_ PULLEYS/IDLERS – Check condition and mountings.
12. \_\_\_ CUTTING EDGES – Check condition of blades, knives.
13. \_\_\_ REELS/ROTORS/CUTTER BARS – Check condition and operation.
14. \_\_\_ LUBRICATE – Lube all fittings, oil or grease all contact points, oil all linkage and pivots per OEM spec.
15. \_\_\_ ENGINE–CHANGE OIL& FILTER, \_\_\_\_\_ qts. Oil # \_\_\_\_\_ Filter # \_\_\_\_\_.
16. \_\_\_ AIR CLEANER – Oil type service \_\_\_\_\_ pts. Dry CHANGE FILTER# \_\_\_\_\_. Check restriction gauge.
17. \_\_\_ FUEL SYSTEM – Drain tank sediment. CHANGE FILTERS # \_\_\_\_\_.
18. \_\_\_ COMPRESSOR – CHANGE OIL & FILTERS \_\_\_\_\_ qts. Oil # \_\_\_\_\_. Filter # \_\_\_\_\_.
19. \_\_\_ EXHAUST SYSTEM – Check muffler and connections for leaks.
20. \_\_\_ BATTERIES – Check condition, cables and terminals.
21. \_\_\_ LIGHTING/SIGNALS – Check all lights, reflectors, wiring \*Replace bulbs as necessary.
22. \_\_\_ STABILIZERS – Check condition and operation, lube.
23. \_\_\_ SAFETY DEVICES – Check all safety equipment.
24. \_\_\_ BRAKES – Check pads, shoes, and drum condition. ADJUST BRAKES PER OEM SPEC.
25. \_\_\_ BRAKES HYDRAULIC – Check and adjust fluid level. Test operate.
26. \_\_\_ BRAKES ELECTRIC – Test operation, wiring and connections, operation of BREAKAWAY DEVICE.
27. \_\_\_ COOLING SYSTEM – CHANGE COOLANT AND FILTER. Adjust temp protected to (-20 to -40) \_\_\_\_\_ degrees.  
Test conditioner concentration & adjust DCA \_\_\_\_\_. Coolant # \_\_\_\_\_. Filter # \_\_\_\_\_.
28. \_\_\_ RADIATOR/FAN – Check water pump, fan. Check radiator fins & air intake screens for restrictions.
29. \_\_\_ HITCH – Check hitch and safety chains.
30. \_\_\_ REPLACE P/M SERVICE STICKER, ADD 5 MONTHS AND 200 HRS.

\*STROBES, FLASHTUBES NOT INCLUDED.

NOTE: Some items applicable only on certain vehicles. Use this guide along with the Manufacturer's maintenance manual to prevent missing recommended service requirements which would void the Manufacturer's equipment warranties.

\_\_\_\_\_  
Shop Supervisor's Signature

\_\_\_\_\_  
Mechanic's Signature

**INDUSTRIAL TRACTOR**  
**TRACTOR W/LOADER, UTILITY TRACTOR, SLOPE MOWER, FORKLIFT**  
**OILS, FLUIDS, FILTERS – MUST MEET OR EXCEED OEM SPECIFICATIONS**

A Service

Vehicle No. \_\_\_\_\_ Hours \_\_\_\_\_ Date \_\_\_\_\_

Place (✓) in blocks that are satisfactory. Place (X) in blocks that are unsatisfactory. Place (N/A) in blocks that do not apply.

1. \_\_\_ INSTRUMENTS AND CONTROLS – Check all instruments, gauges, switches, controls and warning devices.
2. \_\_\_ LIGHTS – Check all lights, mountings and lenses. \*Replace bulbs as needed.
3. \_\_\_ SEAT BELTS – Check fabric, buckles and mounts, service/ability.
4. \_\_\_ BATTERY – Service, check condition, cables and terminals.
5. \_\_\_ STEERING – Check for looseness. Check wheel bearing adjustment.
6. \_\_\_ BRAKES, PARKING BRAKES AND CLUTCH – Check operation. Adjust if needed.
7. \_\_\_ WHEELS AND TIRES – Check tire condition, tighten lug bolts, adjust air pressure.
8. \_\_\_ FRAME, HITCH, ROLL OVER STRUCTURE – Check condition, rust, bent, broken, missing or loose bolts.
9. \_\_\_ HYDRAULIC SYSTEM – Check for leaks, pump, valves, cylinders, and check hoses and lines.
10. \_\_\_ SAFETY EQUIPMENT – Check safety shields, guard and SMV sign. Check backup alarm.
11. \_\_\_ FRONT AXLE – Check for loose bolts, condition.
12. \_\_\_ BELTS AND HOSES – Check tension and service/ability. Adjust tension if needed.
13. \_\_\_ LUBRICATE – Lube all Fittings, oil all control linkage, levers and pivots, per OEM spec.
14. \_\_\_ ENGINE – CHANGE OIL & FILTERS \_\_\_\_\_ qts. Oil# \_\_\_\_\_. Filter# \_\_\_\_\_.
15. \_\_\_ AIR CLEANER – Check condition and restriction gauge, clean element. Service dust valve.
16. \_\_\_ FUEL SYSTEM – Drain tank sediment. CHANGE FILTERS # \_\_\_\_\_
17. \_\_\_ TRANSMISSION – Adjust fluid level \_\_\_\_\_ pts. Fluid # \_\_\_\_\_
18. \_\_\_ REVERSER – Adjust fluid level \_\_\_\_\_ pts. Fluid # \_\_\_\_\_
19. \_\_\_ TRANSAXLE – Adjust fluid level \_\_\_\_\_ pts. Fluid # \_\_\_\_\_
20. \_\_\_ REAR AXLE – Adjust fluid level \_\_\_\_\_ pts. Fluid # \_\_\_\_\_ LUBE AXLE BEARINGS
21. \_\_\_ HYDRAULIC TANK – Adjust fluid level \_\_\_\_\_ pts. Fluid# \_\_\_\_\_.
22. \_\_\_ POWER STEERING – Check and adjust fluid level \_\_\_\_\_ pts. Fluid # \_\_\_\_\_.
23. \_\_\_ BRAKE MASTER CYLINDER – Adjust fuel level \_\_\_\_\_ pts. Fluid # \_\_\_\_\_.
24. \_\_\_ EXHAUST SYSTEM – Check manifold, muffler and connections for leaks.
25. \_\_\_ RADIATOR/FAN – Check fan, water pump, radiator fins for restrictions.
26. \_\_\_ COOLING SYSTEM – Adjust level and temp protected to (-20 to -40) \_\_\_\_\_ degrees. Test conditioner concentration and adjust DCA \_\_\_\_\_ Coolant # \_\_\_\_\_ Filter# \_\_\_\_\_.
27. \_\_\_ CUTTER BAR/MOWER – Check condition.
28. \_\_\_ CUTTING EDGES/MOWER- Check condition of blades.
29. \_\_\_ mast/fork lift – Check slides, bearings, chains, chain tension (deflection) adjust if required.
30. \_\_\_ REPLACE P/M SERVICE STICKER, ADD 5 MONTHS AND 200 HRS.

\*STROBES, FLASHTUBES NOT INCLUDED.

NOTE: Some items applicable only on certain vehicles. Use this guide along with the Manufacturer's maintenance manual to prevent missing recommended service requirements which would void the Manufacturer's equipment warranties.

\_\_\_\_\_  
Shop Supervisor's Signature

\_\_\_\_\_  
Mechanic's Signature

**INDUSTRIAL TRACTOR  
TRACTOR W/LOADER, UTILITY TRACTOR, SLOPE MOWER, FORKLIFT  
OILS, FLUIDS, FILTERS – MUST MEET OR EXCEED OEM SPECIFICATIONS**

C Service

Vehicle No. \_\_\_\_\_ Hours \_\_\_\_\_ Date \_\_\_\_\_

Place (✓) in blocks that are satisfactory. Place (X) in blocks that are unsatisfactory. Place (N/A) in blocks that do not apply.

1.  INSTRUMENTS AND CONTROLS – Check all instruments, gauges, switches, controls and warning devices.
2.  LIGHTS – Check all lights, mountings and lenses. \*Replace bulbs as needed.
3.  SEAT BELTS – Check fabric, buckles and mounts, service/ability.
4.  BATTERY – Service, check condition, cables and terminals.
5.  STEERING – Check for looseness. Check wheel bearing adjustment.
6.  BRAKES, PARKING BRAKES AND CLUTCH – Check operation, adjust as needed.
7.  WHEELS AND TIRES – check tire condition, tighten log bolts, and adjust air pressure.
8.  FRAME, HITCH, ROLL OVER STRUCTURE – Check condition, rust, rent, broken, missing or loose bolts.
9.  HYDRAULICS SYSTEM – check for leaks, valves, cylinders. Check hoses and lines.
10.  SAFETY EQUIPMENT – Check safety shields/guards, SMV sign, back up alarm.
11.  FRONT AXLE – Check for loose bolts, condition.
12.  BELTS AND HOSES – Check tension and serviceability, adjust tension if needed.
13.  LUBRICATE – Lube all fittings, oil control linkage, levers, pivots, per OEM spec.
14.  ENGINE – CHANGE OIL AND FILTERS \_\_\_\_\_ qts. Oil # \_\_\_\_\_ . Filter # \_\_\_\_\_ .
15.  AIR CLEANER – CHANGE AIR FILTER # \_\_\_\_\_ . Service dust valve.
16.  FUEL SYSTEM – Drain tank sediment. CHANGE FILTERS # \_\_\_\_\_ .
17.  TRANSMISSION – CHANGE FLUID & FILTERS \_\_\_\_\_ qts. Fluid # \_\_\_\_\_ . Filter # \_\_\_\_\_ .
18.  REVERSER – CHANGE FLUID AND FILTERS \_\_\_\_\_ qts. Fluid # \_\_\_\_\_ . Filter # \_\_\_\_\_ .
19.  TRANSAXLE – CHANGE FLUID AND FILTERS \_\_\_\_\_ qts. Fluid # \_\_\_\_\_ . Filter # \_\_\_\_\_ .
20.  REAR AXLE – CHANGE FLUID AND FILTERS \_\_\_\_\_ qts. Fluid # \_\_\_\_\_ . Filter # \_\_\_\_\_ .
21.  HYDRAULIC TANK – CHANGE OIL & FILTERS \_\_\_\_\_ qts. Fluid # \_\_\_\_\_ . Filter # \_\_\_\_\_ .
22.  POWER STEERING – Check and adjust fluid level \_\_\_\_\_ pts. Fluid # \_\_\_\_\_ .
23.  BRAKE MASTER CYLINDER – Adjust fluid level \_\_\_\_\_ pts. Fluid # \_\_\_\_\_ .
24.  EXHAUST SYSTEM – Check manifold, muffler and connections for leaks.
25.  RADIATOR/FAN – Check fan, water pump, radiator fins for restrictions.
26.  COOLING SYSTEM – CHANGE COOLANT AND FILTER. Adjust temp. Protected to (-20 to -40) \_\_\_\_\_ degrees. Test conditioner concentration and adjust, DCA \_\_\_\_\_ Coolant # \_\_\_\_\_ Filter # \_\_\_\_\_ .
27.  CUTTER BAR/MOWER – Check condition.
28.  CUTTING EDGES/MOWER – Check condition of blades.
29.  MAST/FORKLIFT – Check slides, bearings, chains, chain tension (deflection) adjust if required.
30.  REPLACE P/M SERVICE STICKER, ADD 5 MONTHS AND 200 HOURS.

\*STROBES, FLASHTUBES NOT INCLUDED.

NOTE: Some items applicable only on certain vehicles. Use this guide along with the Manufacturer's maintenance manual to prevent missing recommended service requirements which would void the Manufacturer's equipment warranties.

\_\_\_\_\_  
Shop Supervisor's Signature  
Tractors C

\_\_\_\_\_  
Mechanic's Signature



## PATTERN FOR VEHICLE MARKING TAPE

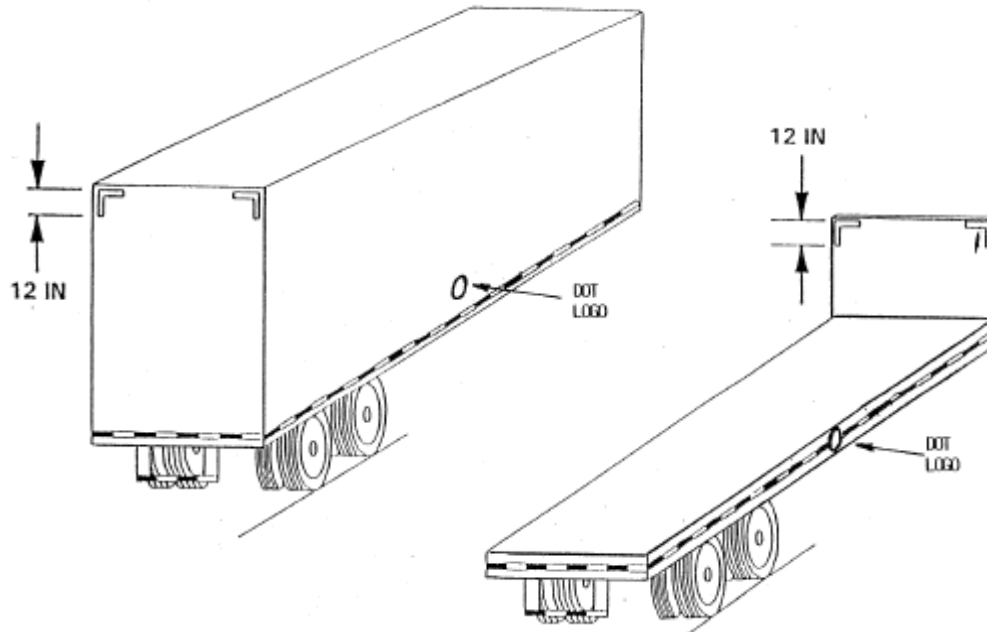

Typical Van and Platform Trailer conspicuity treatments

Vehicle marking tape 2 inch wide red and white



Red stripe 11 inches in length  
White stripe 7 inches in length

### Installation Instructions:

1. Remove all dirt and grease with a cleaning solvent.
2. Apply tape as indicated on marking examples.
3. Smooth tape to eliminate air bubbles.

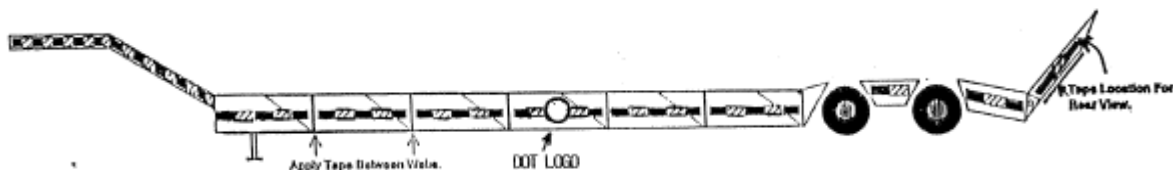

Typical Flatbed Trailer conspicuity treatments

## PATTERN FOR VEHICLE MARKING TAPE



Typical Vehicle conspicuity treatments

## SLOW-MOVING VEHICLE EMBLEM

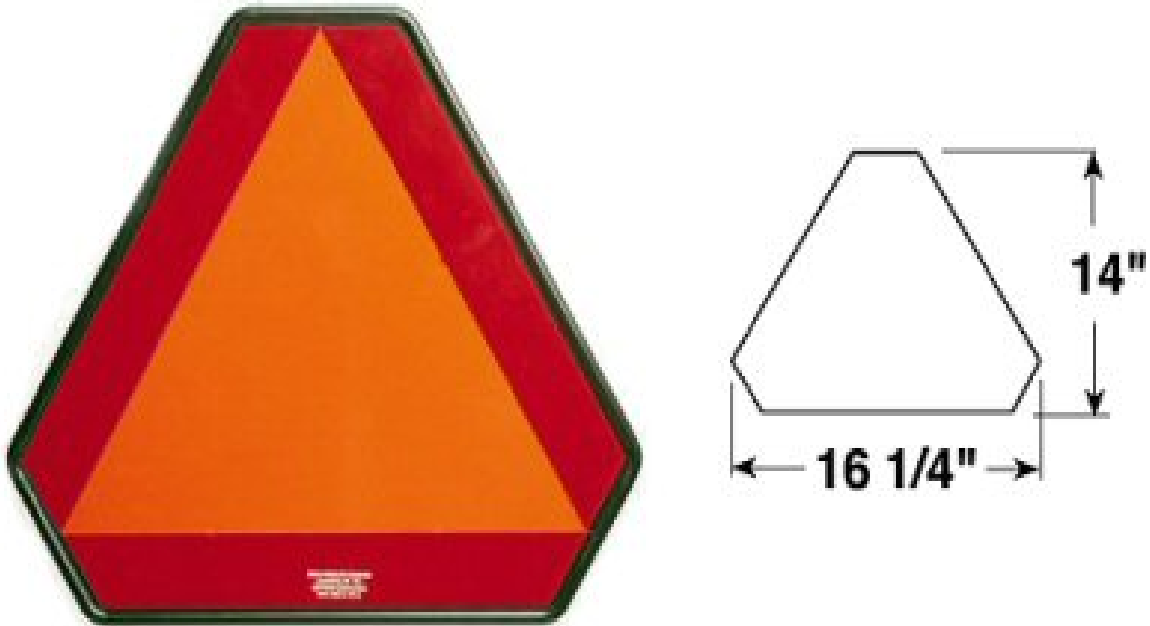

Slow Moving Vehicle Emblem (SMV Emblem) must be certified compliant with ANSI/ASAE S276.3

Size: 16-1/4" wide and 14" high.

Shape: Equilateral triangle, one point up,

Border: 1-3/4" dark red, highly reflective, beaded material.

Center: 12" triangle of yellow-orange fluorescent material.

Location: Rear of vehicle, as near the center of mass as possible, and 2 to 6 feet above ground.

Note: Use ONLY on vehicles that normally travels or is normally used at a speed of less than 25 miles per hour and which is operated on a public highway. This slow-moving vehicle emblem does not replace other safety marker lights or devices required by law.

## MINIMUM MOBILE EQUIPMENT REPLACEMENT CRITERIA

NOTE: As of this document's effective date, a revision to the statewide minimum mobile equipment replacement criteria is being developed by DMS Fleet Management. The final version of the mobile equipment replacement criteria that DMS Fleet Management is revising will be included in this document and will be adopted by the Department when it is published.

The statewide minimum mobile equipment replacement criteria set by DMS Fleet Management. Currently it is set to 12 years or 120,000 miles for standard vehicles up to ½ Ton pickup and 150,000 miles for ¾ Ton and 1 Ton pickups. Other fleet items have a different minimum mobile equipment replacement criteria and they are shown on the following table by fleet code.

Fleet Code	Fleet Code Description	Months	Miles or Hours	Meter	VEU
0010	SEDAN LG SIZE	144	120,000	Miles	2.5
0012	SEDAN MID SIZE	144	120,000	Miles	1.5
0019	SEDN LG SZ BI-FUEL	144	120,000	Miles	1
0020	SEDAN LG SIZE	144	120,000	Miles	1
0029	SEDAN LG SIZE BI-FUEL	144	120,000	Miles	1
0030	SEDAN MID SIZE	144	120,000	Miles	1
0039	SEDAN MID SIZE BI-FUEL	144	120,000	Miles	1
0050	SEDAN SUBCOMPACT	144	120,000	Miles	1
0060	SEDAN COMPACT	144	120,000	Miles	1
0069	SEDAN COMPACT BI-FUEL	144	120,000	Miles	1
0120	STATION WAGON LG SIZE	144	120,000	Miles	1
0130	STATION WAGON MID SIZE	144	120,000	Miles	1
0139	STA WAG MID SIZE BI-FUEL	144	120,000	Miles	1
0150	STATION WAGON SUBCOMPACT	144	120,000	Miles	1
0160	STATION WAGON COMPACT	144	120,000	Miles	1
0200	SUV LG SIZE 4X2	144	120,000	Miles	1.5
0205	SUV LG SIZE 4X4	144	120,000	Miles	2
0209	SUV MID SIZE 4X2 BI-FUEL	144	120,000	Miles	1.5
0219	SUV LG SIZE 4X2 BI-FUEL	144	120,000	Miles	2
0220	SUV LG SIZE 4X2	144	120,000	Miles	2
0221	SUV MID SIZE 4X2	144	120,000	Miles	1.5

Fleet Code	Fleet Code Description	Months	Miles or Hours	Meter	VEU
0225	SUV MID SIZE 4X4	144	120,000	Miles	2
0226	SUV SM SIZE 4X2	144	120,000	Miles	1.5
0229	SUV MID SIZE 4X4 BI-FUEL	144	120,000	Miles	2
0239	SUV LG SIZE 4X4 BI-FUEL	144	120,000	Miles	2
0240	SUV LG SIZE 4X2	144	120,000	Miles	1.5
0249	SUV LG SZ BI-FUEL	144	120,000	Miles	1.5
0300	VAN PANEL 1/2 TON	144	120,000	Miles	1.5
0301	VAN PANEL 3/4 TON	144	120,000	Miles	1.5
0302	VAN PANEL 1 TON	144	120,000	Miles	1.5
0305	VAN STEP	144	120,000	Miles	1.5
0309	VAN BI-FUEL	144	120,000	Miles	1.5
0310	VAN CLUB WAGON 5 PASSENGER	144	120,000	Miles	1
0311	VAN CLUB WAGON 8 PASSENGER	144	120,000	Miles	1
0312	VAN CLUB WAGON 12 PASS	144	120,000	Miles	1.5
0315	15 PASSENGER BUS	144	120,000	Miles	1.5
0316	VAN COMPACT	144	120,000	Miles	1
0317	VAN ECONOMY CARGO	144	120,000	Miles	1
0319	VAN ECONOMY BI-FUEL	144	120,000	Miles	1
0331	< 50 PASS. CONVENTIONAL BUS	144	120,000	Miles	1
0341	>=50 PASS. CONVENTIONAL BUS	144	120,000	Miles	4
0450	1 TON WRECKER	144	120,000	Miles	3
0500	1/2 T PICKUP 4X2	144	120,000	Miles	1.5
0505	1/2 T PICKUP 4X4	144	120,000	Miles	2
0509	1/2 T PICKUP 4X2 BI-FUEL	144	120,000	Miles	1.5
0510	3/4 T PICKUP 4X2	144	150,000	Miles	1.5
0515	3/4 T PICKUP 4X4	144	150,000	Miles	2
0519	3/4 T PICKUP BI-FUEL 4X2	144	150,000	Miles	1.5
0520	3/4 T PICKUP CREW CAB 4X2	144	150,000	Miles	1.5
0525	3/4 T PICKUP CREW CAB4X4	144	150,000	Miles	2
0530	1 TON PICKUP 4X2	144	150,000	Miles	1.5
0535	1 TON PICKUP 4X4	144	150,000	Miles	2
0540	1 TON PICKUP CREW CAB	144	150,000	Miles	1.5



Fleet Code	Fleet Code Description	Months	Miles or Hours	Meter	VEU
0550	COMPACT PICKUP	144	120,000	Miles	1.5
0551	COMPACT PICKUP DIESEL	144	120,000	Miles	1.5
0555	COMPACT PICKUP 4X4	144	120,000	Miles	1.5
0559	COMPACT PICKUP BI-FUEL	144	120,000	Miles	1.5
0560	MID SIZE PICKUP	144	120,000	Miles	1.5
1000	TRUCK 2 TON CAB CHASSIS	120	150,000	Miles	3
1001	TRUCK 2 TON FLAT BED	120	150,000	Miles	3
1002	TRUCK 2 TON FL BED DUMP	120	150,000	Miles	3
1010	TRUCK 2 TON HERBICIDE COE	120	150,000	Miles	3
1030	TRUCK 28 FT BUCKET	120	150,000	Miles	4
1040	TRUCK WELDING MACH MTD	120	150,000	Miles	3
1041	TRUCK STAKE BED	120	150,000	Miles	3
1050	TRUCK GUARDRAIL MACHINE MTD	120	150,000	Miles	5
1100	TRUCK CREW CAB	120	150,000	Miles	3
1101	TRUCK 2 TON CREW DUMP	120	150,000	Miles	3
1105	TRUCK MODULAR CREW CAB	120	150,000	Miles	3
1110	TRUCK EJECTION DUMP	120	150,000	Miles	5
1111	TRUCK ASPHALT PATCH	120	150,000	Miles	5
1200	TRUCK SIGN	120	150,000	Miles	3
1201	TRUCK SIGN W/PLATFORM	120	150,000	Miles	5
1202	TRUCK SIGN W/PLATFORM LG	120	150,000	Miles	5
1211	TRUCK BRIDGE CRANE TANDEM	120	150,000	Miles	5.5
1220	TRUCK 45 FT BUCKET	120	150,000	Miles	5
1221	TRUCK 60 FT BUCKET	120	150,000	Miles	5
1230	TRUCK VERTICLE LIFT	120	150,000	Miles	4
1235	TRAILER MTD VERTICLE LIFT	144	4,000	Hours	2
1241	TRUCK 50 FT BRIDGE INSP MACH	144	5,000	Hours	6
1242	TRUCK 60 FT BRIDGE INSP MACH	144	5,000	Hours	6
1245	TRLR MTD UNDER BRDG INSP MACH	144	4,000	Hours	6
1255	CAR HAULER	144	150,000	Miles	3
1301	TRUCK CENTERLINE LG DIESEL	144	10,000	Hours	5
1310	TRK CENTERLINE SUPPORT 26GVW	144	250,000	Miles	3

Fleet Code	Fleet Code Description	Months	Miles or Hours	Meter	VEU
1311	TRK CENTERLINE SUPPORT 33GVW	144	250,000	Miles	3
1401	SWEeper LOW DUMP	144	5,000	Hours	6.5
1402	SWEeper 8 YD	144	5,000	Hours	6.5
1405	SWEeper HIGH DUMP	144	5,000	Hours	6.5
1415	SWEeper TRACTOR MTD	144	4,000	Hours	3
1420	SEWER CLEANER 8 YD CAPACITY	144	5,000	Hours	6.5
1421	SEWER CLEANER 16 YD CAPACITY	144	5,000	Hours	6.5
1500	TRUCK 4 YD DUMP	144	150,000	Miles	3
1501	TRUCK 4 YD DUMP LWB	144	150,000	Miles	3
1502	TRUCK 4 YD DUMP	144	150,000	Miles	3
1510	TRUCK 8 YD DUMP	144	250,000	Miles	4.5
1511	TRUCK 14 YD DUMP	144	250,000	Miles	4.5
1520	TRUCK LG WRECKER	144	250,000	Miles	4
1545	TRUCK 1 TON	144	150,000	Miles	1.5
1600	TRUCK ASPHALT DISTRIBUTOR	144	150,000	Miles	5
1620	TRUCK WATER TANKER	144	150,000	Miles	4
1621	TRUCK WATER-DRILL-TANDEM AXLE	144	250,000	Miles	4
1650	TRUCK DUTCH CONE PENETROMETR	144	250,000	Miles	5
1702	TRUCK TRACTOR TNDM AXLE	144	250,000	Miles	4
2002	TRK 35 T CRANE D-LINE (1 YD)	144	8,000	Hours	6
2010	EXCAVATOR	144	8,000	Hours	4
2011	EXCAVATOR LARGE	144	8,000	Hours	4
2012	EXCAVATOR BACKHOE	144	8,000	Hours	4
2015	EXCAVATOR	144	8,000	Hours	4
2100	SOIL MIXER SELF PROPELLED	144	8,000	Hours	2
2110	SOIL MIXER TRACTOR MTD	120	5,000	Hours	1
2111	SOIL MIXER LARGE	120	5,000	Hours	2
2120	HARROW DOUBLE DISC	120	5,000	Hours	1
2130	CULTIPACKER	120	5,000	Hours	0.5
2150	AERATOR	120	5,000	Hours	1
2151	MED DUTY TURF AERATOR	84	5,000	Hours	1
2200	MOTOR GRADER 75 HP	144	7,000	Hours	4

Fleet Code	Fleet Code Description	Months	Miles or Hours	Meter	VEU
2210	MOTOR GRADER DSL 120 HP	144	7,000	Hours	4
2215	MOTOR GRADER SPECIAL	144	7,000	Hours	4
2232	TRENCH MACHINE TRACT MTD LARGE	120	4,000	Hours	3
2302	TRACTOR LOADER	120	4,000	Hours	3.5
2305	TRACTOR LOADER BACKBLADE	120	4,000	Hours	4
2310	WHEEL LOADER 2 YD	120	5,000	Hours	4
2311	WHEEL LOADER 3 YD	120	5,000	Hours	4
2315	SKID STEER LOADER	120	5,000	Hours	3.5
2320	TRACTOR LOADER BACKHOE LARGE	120	5,000	Hours	4
2321	TRACTOR LOADER BACKHOE	120	5,000	Hours	4
2400	BULLDOZER CRAWLER	120	5,000	Hours	5
2401	ANGLE BULLDOZER CRAWLER	120	5,000	Hours	5
2510	ROLLER 3-5 T TANDM SELF PROP	144	4,000	Hours	5
2520	ROLLER 4-6 T TANDM SELF PROP	144	4,000	Hours	5
2530	ROLLER 8-12 T TANDM SELF PROP	144	4,000	Hours	3
2541	ROLLER VIB PORTABLE (800-900#)	144	4,000	Hours	3
2542	ROLLER VIB TANDEM SMALL	144	4,000	Hours	2
3002	MOWER ROTARY 6FT LIFT PULL	60	4,000	Hours	1
3004	MOWER HEAVY DUTY 80 IN	60	4,000	Hours	1
3005	MOWER ROTARY LIFT 80 IN	60	4,000	Hours	1
3006	MOWER ROTARY PULL 7 FT	60	4,000	Hours	1
3010	MOWER ROTARY 10 FT	60	4,000	Hours	1
3020	MOWER ROTARY 15 FT	60	4,000	Hours	1
3021	MOWER ROTARY TRCT HYD 15 FT	60	4,000	Hours	1
3030	MOWER FLAIL	60	4,000	Hours	1
3031	MOWER FLAIL	60	4,000	Hours	1
3032	MOWER FLAIL LIFT 7 FT	60	4,000	Hours	1
3040	MOWER ROTARY SELF PROPELLED	60	4,000	Hours	2
3041	TRACTOR LAWN GARDEN (GAS)	60	4,000	Hours	2
3042	MOWER ROTARY RIDING	60	4,000	Hours	2
3045	MOWER SLOPE SELF PROP	60	3,000	Hours	2
3100	TRACTOR 19 HP	96	3,000	Hours	2.5



Fleet Code	Fleet Code Description	Months	Miles or Hours	Meter	VEU
3120	TRACTOR 54 HP	120	4,000	Hours	2.5
3121	TRACTOR 68 HP	120	4,000	Hours	3
3122	TRACTOR 85 HP	144	5,000	Hours	3
3125	TRACTOR 56 HP LCG	96	4,000	Hours	2.5
3130	TRACTOR W/SLOPE MOWER	96	4,000	Hours	4
3132	TRACTOR W/ART BOOM ROT MOWER	96	4,000	Hours	4
3135	TREE AND BRUSH TRIM H.D. ART.	96	3,000	Hours	2.5
3201	SID MTD SPRAYER 300 GAL	120	5,000	Hours	1.5
3202	TRAILER MTD SPRAYER 400 GAL	120	5,000	Hours	2
3204	SKID MTD SPRAYER 500 GAL	120	5,000	Hours	1.5
3210	PORTABLE STRIPING MACH 2 LINE	120	5,000	Hours	1
3211	PORTABLE STRIPING MACH 1 LINE	120	5,000	Hours	1
3212	THERMOPLASTIC MACHINE	120	5,000	Hours	1
3216	SKID MTD ADHESIVE DISP	60	3,000	Hours	1
3220	SEWER CLEANER WITH TRAILER	120	5,000	Hours	
3305	TRK MTD BULK DISTRIBUTOR	60	5,000	Hours	1.5
3310	SPREADER SAND	120	5,000	Hours	
3320	SPREADER BOX	120	5,000	Hours	0.25
3321	SHOULDERING MACHINE	120	5,000	Hours	0.5
3340	TRLR MTD MULCH BLOWER	120	2,500	Hours	2
3401	ASPHALT KETTLE W/HEAT	120	4,000	Hours	1
3411	ASPHALT PAVER SELF PROP	120	4,000	Hours	5
3412	ASPHALT MAINTAINER	120	4,000	Hours	1
3500	CONCRETE MIXER PORT 8 CU FT	120	4,000	Hours	1
3510	GROUT MACHINE	120	4,000	Hours	1.5
3520	MUD JACK	120	4,000	Hours	1.5
3530	CONCRETE MIXER PORT 6 CU FT	120	4,000	Hours	1
3531	CONCRETE MIXER PORT 11 CU FT	120	4,000	Hours	1
3532	CONCRETE MIXER PORT 1.75 YD	120	4,000	Hours	1
3540	CONCRETE SAW	120	4,000	Hours	0.5
3600	TRAILER MTD WOOD CHIPPER	120	4,000	Hours	2
3610	MULCH CUTTER AND ROLLER	120	4,000	Hours	1.5

Fleet Code	Fleet Code Description	Months	Miles or Hours	Meter	VEU
3615	SEEDER	120	4,000	Hours	1
3620	STUMP CUTTER	120	4,000	Hours	1
3621	TREE CUTTER ROTARY PULL	120	4,000	Hours	1
3630	CURB DRESSER AUTO POWER	120	4,000	Hours	1
3660	PORTABLE LINE REMOVER	120	4,000	Hours	1
4000	TRAILER LB 25 TON	144	5,000	Hours	0.5
4001	TRAILER LB 35 TON 8 FT WIDE	144	5,000	Hours	0.5
4002	TRAILER LB 35 TON 10 FT WIDE	144	5,000	Hours	0.5
4003	TRL 35T 10 FT WIDE DROP DK	144	5,000	Hours	0.5
4004	TRL 50T 10 FT WIDE	144	5,000	Hours	0.5
4010	TRAILER LOW BED	144	5,000	Hours	0.5
4020	TRAILER FB 9 TON	144	5,000	Hours	0.5
4021	TRAILER FB 45 FT 5TH WHEEL	144	5,000	Hours	1
4025	TRAILER HAY 18,000 LB	144	5,000	Hours	0.5
4026	TRAILER GOOSENECK 4 TON TA	144	5,000	Hours	0.5
4030	TRAILER TILT S/A	144	5,000	Hours	0.5
4032	TRAILER 28 FT GOOSENECK	144	5,000	Hours	0.5
4040	TRAILER TILT D/A 12 TON	144	5,000	Hours	0.5
4045	TRAILER TILT 15 TON	144	5,000	Hours	0.5
4050	TRAILER TILT TA 9 TON	144	5,000	Hours	0.5
4060	TRAILER TILT 16 TON	144	5,000	Hours	0.5
4070	TRAILER UTILITY LOW BED 6 TON	144	5,000	Hours	0.5
4080	TRAILER UTILITY	144	5,000	Hours	0.5
4081	TRAILER UTILITY MOT SAFETY	144	5,000	Hours	0.5
4090	TRAILER HB 40 TON	144	5,000	Hours	0.5
4095	TRAILER BRIDGE TEST	144	5,000	Hours	3
4100	TRAILER SEMI VAN	144	5,000	Hours	1
4110	TRAILER TESTING, CHLOE	144	5,000	Hours	1.5
4114	TRAILER SCALES	144	5,000	Hours	1
4120	TRAILER RADIO	144	5,000	Hours	0.5
4121	TRAILER DYNAMIC DEFLECT	144	5,000	Hours	1.25
4130	TRAILER SIGN WITH LIFT	144	5,000	Hours	0.5

Fleet Code	Fleet Code Description	Months	Miles or Hours	Meter	VEU
4200	TRAILER TANK WATER	144	5,000	Hours	1
4310	TRAILER MATERIALS	144	5,000	Hours	0.5
4320	TRAILER OFFICE	144	5,000	Hours	1
4400	TRAILER POLE	144	5,000	Hours	0.5
4420	TRAILER BOAT 16 FT OR LESS	144	5,000	Hours	0.5
4430	TRAILER ROCK DUMP	144	5,000	Hours	0.5
4460	TRAILER MUD BUG	144	5,000	Hours	0.5
4470	TRAILER PENETROMETER	144	5,000	Hours	1.5
4510	TRAILER SKID TEST	144	5,000	Hours	1.5
4511	VAN SKIDTEST AIRPORT	96	70,000	Miles	1.5
5200	DEFLECTION TEST TRUCK	96	95,000	Miles	1.5
5531	1 TON PICKUP SKIDTEST MAT	96	95,000	Miles	1.5
9000	PUMP CENTRIFUGAL 4 INCH	120	4,000	Hours	0.5
9011	PUMP CENTRIFUGAL 6 X 6 INCH	120	4,000	Hours	0.5
9012	PUMP CENTRIFUGAL 8 X 8 INCH	120	4,000	Hours	0.5
9020	PUMP DIAPHRAM DOUBLE	120	4,000	Hours	0.5
9111	AIR COMPRESSOR 150 CFM	120	4,000	Hours	0.5
9112	AIR COMPRESSOR 250 CFM	120	4,000	Hours	0.5
9140	AIR COMPRESSOR 750 CFM	120	4,000	Hours	0.5
9200	GENERATOR UNDER 25 KW	120	4,000	Hours	2
9201	GENERATOR OVER 25 KW	120	4,000	Hours	2
9210	CORE DRILL PORT W/GENERATOR	120	4,000	Hours	2.5
9230	GENERATOR DRILL COMBINATION	120	4,000	Hours	2.5
9250	ARC WELDERS PORTABLE	120	4,000	Hours	0.5
9251	ARC WELDERS PORTABLE 200 AMP	120	4,000	Hours	0.5
9254	ARC WELDER PORTABLE 400 AMP	120	4,000	Hours	0.5
9260	TRAILR MTD ARC WELDER 200 AMP	120	4,000	Hours	0.75
9261	TRAILR MTD ARC WELDER 300 AMP	120	4,000	Hours	0.75
9270	TRAILER MTD ARROW BOARD	120	20,000	Hours	1
9271	TRAILER MTD MESSAGE BOARD	120	20,000	Hours	1
9272	TRAILER MTD TRAFFIC SIGNAL	120	20,000	Hours	1
9273	TRLR MTD SOLAR ARROW BOARD	120	20,000	Hours	1

<b>Fleet Code</b>	<b>Fleet Code Description</b>	<b>Months</b>	<b>Miles or Hours</b>	<b>Meter</b>	<b>VEU</b>
9274	TRLR MTD SOLAR MESSAGE BOARD	120	20,000	Hours	1
9279	TRAILER MTD FLOOD LGTS	120	5,000	Hours	1
9300	BOATS LIGHT DUTY UP TO 18 FT	96	5,000	Hours	0.5
9310	BOAT WORK UP TO 18 FT	96	5,000	Hours	0.5
9320	BOAT LIGHT DUTY 18 FT & UP	96	5,000	Hours	0.5
9330	BOAT WORK 18 FT & UP	96	5,000	Hours	0.5
9350	BARGE	96	5,000	Hours	0.5
9360	OUTBOARD MOTORS ALL	72	1,000	Hours	0.5
9410	TRUCK MTD CORE DRILL LIGHT	144	5,000	Hours	4
9412	TRUCK MTD CORE DRILL HEAVY	144	5,000	Hours	4
9420	TRAILER MTD CORE DRILL PAVMT	144	5,000	Hours	4
9442	TRUCK MTD DRILL RIG	120	250,000	Miles	4
9450	ATV MTD DRILL	144	5,000	Hours	1
9451	TRACKED ATV	144	5,000	Hours	1
9460	ATV ARTIC DRILL IND ROT	144	5,000	Hours	1
9475	ALL TERRAIN VEHICLE	48	1,200	Hours	2
9600	FORK LIFT TRUCK 2,500 LB	120	4,000	Hours	2
9601	FORK LIFT TRUCK 4,000 LB	120	4,000	Hours	2
9602	FORK LIFT TRUCK 6,000 LB	120	4,000	Hours	2
9610	FORK LIFT WAREHOUSE 5,000 LBS	120	4,000	Hours	2
9615	FORK LIFT ELECTRIC 5,000 LBS	120	4,000	Hours	2
9620	FORK LIFT TRUCK 10,000 LB	120	4,000	Hours	6
9700	AIRCRAFT	240	20,000	Hours	3
9720	MOTOR HOME	120	100,000	Miles	0.5

FDOT Fleet Quality Assurance Review Program  
**QAR Requirements and Compliance Indicators for FDOT Fleet Management**

Highlighted Measures are **currently** included on the Department QAR Program

Fleet MT Category	Measure #	Proposed Critical Requirement	Proposed Review Process	Proposed Compliance Indicators	Year 1	Year 2	Year 3
<b>General Fleet Management</b>	1	Fleet Effectiveness	Compare depreciation and operating costs to predefined benchmarks	Fleet depreciation and operating costs meet benchmark	Identify data sources for per vehicle purchase cost, remarketing proceeds, repair and maintenance cost, accident repair cost, gas cost, miles. Ensure appropriate class code is assigned to each vehicle. Determine method for compiling data by vehicle class. Calculate costs per mile for each class for a 12 month period for depreciation, maintenance and repair, accident repair, and gas.	Calculate costs and compare to Year 1. Target: 10% Decrease Identify targets and external benchmark(s) for year 3	Calculate costs and compare to Year 2. Compare against target and external benchmarks. Identify targets and external benchmark(s) for year 4. <b>Ongoing Requirement</b>
	2	Fleet Effectiveness	Scheduled periodic review of replacement and utilization parameters, vehicle specifications, and methods of acquisition, financing, disposal, maintenance and fuel to ensure best practice, effectiveness and efficiencies.	Service methods review and comparative analysis completed in accordance with schedule, actions plans developed, and plan execution targets met.	Begin process using current fleet review final report as basis for best practices. Develop plan and action item list to implement 2008 Fleet report recommendations.	Measure progress against Year 1 plan (dates met, results accomplished) Develop schedule for reviewing parameters at least one factor reviewed each year.	Execute review plan, complete scheduled review, develop tactical plan for improvement. <b>Ongoing Requirement</b>

Fleet MT Category	Measure #	Proposed Critical Requirement	Proposed Review Process	Proposed Compliance Indicators	Year 1	Year 2	Year 3
	3	Fleet Effectiveness	Conduct bi-annual customer satisfaction survey.	Overall customer satisfaction rating of 90% regarding fleet services		Design customer survey to elicit feedback on key fleet functions (vehicle selection, purchase process, replacement process, remarketing process, maintenance and repair process and quality and general fleet service). Determine survey questions and method to execute using best practice methodology.	Conduct survey, analyze results, and develop tactical plan to address issues and report findings and proposed actions to customers. <b>Ongoing bi-annual requirement</b>
	4	Fleet roles and responsibilities are clearly delineated	Compare salary and wage list to org chart	Organizational chart and job descriptions in place	Review current org charts with Districts and ensure they are complete and accurate. Identify method to update data annually.	Execute Update Process. <b>Ongoing Requirement</b>	<b>Ongoing Requirement</b>
	5	Fleet policies and drivers' guides are up-to-date and distributed to fleet users	Compare any notices of fleet policy distributed in past 12 months against Mobile Equipment Manual (MEM)	MEM is current and distributed	Revise and re-publish MEM. Develop process that ensures MEM is updated when any change in policy or practice occurs.	Execute Update Process. <b>Ongoing Requirement</b>	<b>Ongoing Requirement</b>

Fleet MT Category	Measure #	Proposed Critical Requirement	Proposed Review Process	Proposed Compliance Indicators	Year 1	Year 2	Year 3
	6	Continuity of Operations Plan for equipment required during emergencies is in place	Compare list of mobile equipment to current inventory. Verify with DMS contracts are in place.	Frontline mobile equipment and contact list exists and is up to date. Contract rental source agreements in place.	Develop list of mobile equipment with locations and contact names and phone numbers. Distribute fleet wide list to each district and FDOT emergency contacts. Determine method for completing ongoing updates.	Select date for annual update of lists and execute. Identify mobile equipment type most needed in emergencies and develop proposals for to contract for the mobile equipment. Work with DMS to secure contracts. Develop schedule for contract review and renewal.	Spot check mobile equipment lists to determine if regular updates are being completed. Review and renew contracts in accordance with schedule. <b>Ongoing Requirement</b>
	7	Multi-year written fleet plan in place and implemented	Review fleet plan to identify current and anticipated vehicle and mobile equipment needs, and seasonal requirements. Develop vehicle selector and prioritize replacements.	Current Fleet Plan in place. Scheduled class reviews completed; specifications and selectors in place.	Utilize fleet replacements plan provided in Mercury report as starting point. Develop method to rank vehicles on replacement list. Publish priority rankings and secure replacements. <b>annually</b>	For the most used classes of vehicles, review vehicle application in field and determine base needs. With input of automotive companies/engineers determine key specifications and develop selector. <b>Update biannually</b>	For all vehicle classes not completed in year 2, review vehicle application in field and determine base needs. With input of automotive companies/engineers determine key specifications and develop selector. <b>Update periodically</b>
	8	Appropriate action taken all items on critical requirement list	List each action required for the year and identify status at year end. Calculate percentage of items completed.	Target-100% of action items completed. Written list of findings with actions taken and dates is in place	Create list for year (year 1 in this case). Note status at year end. Calculate the number of items completed in accordance with plan. Target:100% <b>Ongoing Requirement</b>	<b>Ongoing Requirement</b>	<b>Ongoing Requirement</b>

Fleet MT Category	Measure #	Proposed Critical Requirement	Proposed Review Process	Proposed Compliance Indicators	Year 1	Year 2	Year 3
	9	Appropriate action taken on prior Department Level QAR findings and recommendations	List each action required as part of Department QAR follow-up and identify status quarterly until all actions are complete. Calculate percentage of items completed.	Written list of findings with actions taken and dates is in place Target - 100% complete. <b>Ongoing Requirement</b>	<b>Ongoing Requirement</b>	<b>Ongoing Requirement</b>	<b>Ongoing Requirement</b>
	10	Utilization of Mobile Equipment Properly Reported	Review reports for mobile equipment log submittals and mobile equipment utilization. Review and determine mobile equipment utilization average by each district.	75% of passenger vehicles have an average utilization that is greater than 50% and less than 175% of the district-wide average utilization for the previous 12 months.	<b>Ongoing Requirement</b>	<b>Ongoing Requirement</b>	<b>Ongoing Requirement</b>
	11	Utilization of Heavy Mobile Equipment Properly Reported	Review reports for heavy mobile equipment log submittals and heavy mobile equipment utilization. Review and determine heavy mobile equipment utilization average by each district.	75% of heavy mobile equipment metered in miles have an average utilization that is greater than 50% and less than 175% of the district-wide average utilization for the previous 12 months. The hour meter items have a minimum threshold of 728 hours.			



Fleet MT Category	Measure #	Proposed Critical Requirement	Proposed Review Process	Proposed Compliance Indicators	Year 1	Year 2	Year 3
<b>Fleet Inventory/Asset/Availability Controls</b>	12	All mobile equipment is accounted for and accurate records exist in FMS for all mobile equipment on hand	Physical inventory of all mobile equipment is performed annually.	100% of mobile equipment is accounted for and mileage is verified during inventory process	Develop process to complete field inventory to verify vehicle license, location and mileage (statewide, same day)	Execute field inventory <b>Annual requirement</b>	<b>Ongoing bi-annual requirement</b>
	13	Vehicles are acquired in compliance with policy	Mobile equipment is acquired in accordance with approved mobile equipment acquisition process. Conduct random sample check annually	100% Compliance	<b>Ongoing requirement</b>	<b>Ongoing requirement</b>	<b>Ongoing requirement</b>
	14	Alternative Fuel Vehicle Requirements	Check numbers of units against target annually	100 % of target met	<b>Ongoing requirement</b>	<b>Ongoing requirement</b>	<b>Ongoing requirement</b>
	15	Vehicles are assigned and disposed of in compliance with policy	Review of mobile equipment receipt, inventory records and mobile equipment disposal forms (6401s). Conduct random sample check annually.	95% of mobile equipment assigned and disposed of within established time frames	<b>Ongoing requirement</b>	<b>Ongoing requirement</b>	<b>Ongoing requirement</b>

Fleet MT Category	Measure #	Proposed Critical Requirement	Proposed Review Process	Proposed Compliance Indicators	Year 1	Year 2	Year 3
	16	Fleet Renewal	Calculate the % of mobile equipment that exceeds replacement criteria and compare to target	<i>Initial:</i> Percentage of fleet that exceeds replacement criteria has remained steady or declined in the last year. <i>Long Term:</i> 95% of mobile equipment replaced in accordance with replacement criteria.	Calculate the % of mobile equipment that exceeds replacement criteria at year end	Calculate the % of mobile equipment that exceeds replacement criteria at year end. Target - Less than prior year  <b>Ongoing requirement</b>	<b>Ongoing requirement</b>
	17	Fleet Availability	Mobile equipment is ready for service when needed versus in the shop. Calculate percentage by district and statewide (number of vehicles available for service/total number of vehicles).	95 % of mobile equipment is ready and available for service	Develop method for recording the number of vehicles with an open work order each day and compiling the information monthly by district. Ensure work orders are opened as soon as a vehicle is dropped off for service and closed when customer is notified vehicle is ready for pick up. Create report that indicates inventory numbers by district using shop code as location indicator to determine numbers by district. Develop spreadsheet with monthly numbers by district (average vehicle with work orders per day and # of vehicles).	Monthly secure inventory and work order numbers. Calculate average number of vehicles down each day for each month and for full year. Calculate percentage available (100% - average % down). Full Year Target: 95% available. <b>Ongoing requirement</b>	<b>Ongoing requirement</b>
	18	Vehicles are fully utilized or are rotated to promote better utilization	During the last 12 months, number of "mileage" vehicles with less than 6,000 miles usage, or mobile equipment with less than 500 hours usage.	Less than 10% of fleet is below minimum mileage/hours targets	Develop vehicle utilization report that lists each vehicle by district and calculates the percentage below target using FMS/monthly log data or fuel transaction data information.	Secure report on usage for a 12 month period. Develop process for reviewing all vehicles below mileage targets and execute. Process must require that the # of day's usage per month are supplied for any vehicle that does not meet targets.	Review mileage targets by class to determine if class specific targets should be developed - applying breakeven alternatives analysis where appropriate. <b>On-going requirement to conduct annual</b>

Fleet MT Category	Measure #	Proposed Critical Requirement	Proposed Review Process	Proposed Compliance Indicators	Year 1	Year 2	Year 3
						<b>On-going requirement</b>	<i>reviews and periodic breakeven analysis.</i>
	<b>19</b>	Operators adhere to vehicle specifications and operator requirements	Annual license check of all operators.	Operator license current and meets mobile equipment requirements	Identify mobile equipment requiring special licenses, obtain list of drivers and license information. Ensure licenses meet requirements and are active.	Secure license numbers for all drivers of FDOT vehicles. Work with Human Resources and License bureau to develop a process for annual checks to determine that licenses are active.	<b>Ongoing requirement</b>
	<b>20</b>	Vehicles are operated in a safe manner	Number of accidents per million miles driven	Accident Rates meet benchmark	Develop method to compile data on the number of accident occurrences each month. Secure accident rate benchmarks from similar fleets and/or industry data.	Using data at year end, calculate the accident rate and compare to benchmark. <b>Ongoing requirement</b>	<b>Ongoing requirement</b>
	<b>21</b>	Accidents/Incidents are reviewed and reported upon properly	Formal accident review process	Accidents/Incidents coded, reviews completed in accordance with policy			Develop and execute accident coding, reporting and review process
	<b>22</b>	Passing of Florida Highway Patrol-Commercial Vehicle Enforcement (FHP-	Inspection of mobile equipment fleet by Motor Carrier Compliance and calculation of	90% of the trucks inspected by FHP-CVE remain in service.	<b>Ongoing requirement</b>	<b>Ongoing requirement</b>	<b>Ongoing requirement</b>

Fleet MT Category	Measure #	Proposed Critical Requirement	Proposed Review Process	Proposed Compliance Indicators	Year 1	Year 2	Year 3
		CVE) Inspections	the percentage that remain in service and number of minor defects				
				Averages of 0.5 or fewer minor defects are identified per truck inspected by FHP-CVE.	<b>Ongoing requirement</b>	<b>Ongoing requirement</b>	<b>Ongoing requirement</b>
<b>Fleet Management Information</b>	<b>23</b>	Vehicle data in Fleet Systems is current and accurate	Mileage Reports are Current and Accurate - Utilize FMS report and random sample checks	Data is tracked and entered in system in accordance with policy; Targets: Reporting 95%; Accuracy 99%	Develop exception report that lists vehicles that did not report miles/hrs. each month, the number of months not reported on time year to date and the percentage of the fleet they represent: Target 95% Reporting on Time Conduct quarterly random sample checks of mileage on odometer vs. mileage in FMS in each district and compile statistics statewide. Continue until target is met for at least 12 months. Target: 99% of sample is accurate.	<b>Reporting is ongoing requirement</b>	<b>Reporting is ongoing requirement</b>

Fleet MT Category	Measure #	Proposed Critical Requirement	Proposed Review Process	Proposed Compliance Indicators	Year 1	Year 2	Year 3
	24	Vehicle data in Fleet Systems is current and accurate	Mechanic Hours are current and accurate; Mechanics are fully utilized	Data is tracked and entered in system in accordance with policy; target: 95% or more accurate. Mechanic utilization target: 70% productive rate.	Develop FMS report of labor hours by mechanic with summaries by shop, district and statewide. Conduct monthly random sample checks on work orders to system for accuracy. Continue until target is met for at least 12 months. Target: 95% of sample is accurate.	Develop spread sheet that compares labor hours in FMS to payroll hours by mechanic. Calculate percent average hours per mechanic in FMS and productive rate percentage based on full year of hours. Target: 70% <b>Ongoing requirement</b>	<b>Mechanic utilization is an ongoing requirement</b>
	25	Vehicle data in Fleet Systems is current and accurate	Parts data is current and accurate	Data is tracked and entered in system in accordance with policy; target: 95% accuracy	Redefine parts purchase categories in FMS to ensure commercial parts and shop parts are separated. Train field on data entry accordingly. Conduct monthly random sample checks on work orders to system for accuracy. Continue until target is met for at least 12 months. Target: 95% of sample is accurate.		

Fleet MT Category	Measure #	Proposed Critical Requirement	Proposed Review Process	Proposed Compliance Indicators	Year 1	Year 2	Year 3
	26	Vehicle data in Fleet Systems is current and accurate	Commercial Repair Data is current and accurate	Data is tracked and entered in system in accordance with policy; target: 95% accuracy	Redefine repair codes to isolate commercial repairs from in-house sample to ensure accuracy. Conduct monthly random sample checks on work orders to system for accuracy. Continue until target is met for at least 12 months. Target: 95% of sample is accurate.		
	27	Vehicle data in Fleet Systems is current and accurate	Fuel Use Data is current and accurate	Data is tracked and entered in system in accordance with policy; Target: exceptions are less than 5% of fleet.		Ensure all fuel usage data is being reported in FMS. Create a fuel usage report by vehicle, with summary miles per gallon and cost per mile by class monthly and year to date. Create exception report quarterly that identifies vehicles that appear to be under reporting and develop and execute a follow up process.	<b>Exception report is an ongoing requirement</b>
	28	Shop operational costs are compiled regularly	Each district has completed template submitted to Central Fleet Office in accordance with schedule	Annual Shop Operation Expense Report is complete and current	With assistance from financial staff develop and refine template for FMs to collect appropriate data in standardized form. Conduct training for district FM and	Review and evaluate data template; consider ability to collect data at shop level. Compile year end data for each district and total for fleet.	<b>Year-end data report is an ongoing requirement</b>

Fleet MT Category	Measure #	Proposed Critical Requirement	Proposed Review Process	Proposed Compliance Indicators	Year 1	Year 2	Year 3
					financial staff. Compile year end data for each district and total for fleet.		
	29	Shop labor rates are updated annually		Labor rate methodology and annual update are complete and documented	Implement rates from fleet study as a starting point; use for 1 year	Use finalized information for shop expenses and labor distribution forecasts to calculate labor rates annually. Update rates in FMS.	<b>Annual rate update is on ongoing requirement</b>
<b>Maintenance</b>	30	Maintenance and repair cost	Total Maintenance and repair cost per vehicle equivalent per year	Maintenance cost per VEU meets benchmark			Develop VEU for FDOT classes utilizing FMS data. Calculate maintenance cost per VEU. Compare cost to current industry trend data.
	31	Preventive Maintenance (PM) properly performed and documented	Review of PM report for Maintenance Unit and District.	95% of PM work completed in accordance with schedule	Review of PM report for Maintenance Unit and District.	<b>Ongoing Requirement</b>	<b>Ongoing Requirement</b>
	32	Preventive Maintenance (PM) properly performed and documented	Review of inspection records for aerial devices.	100% compliance with required OSHA and ANSI inspections for aerial mobile equipment.	Review of inspection records for aerial devices.	<b>Ongoing Requirement</b>	<b>Ongoing Requirement</b>

Fleet MT Category	Measure #	Proposed Critical Requirement	Proposed Review Process	Proposed Compliance Indicators	Year 1	Year 2	Year 3
	33	Quality of repair service meets or exceeds commercial standards	Quality	Repeat repairs less than 2% of total work orders			Establish criteria for "repeats", develop codes to be used in FMS, and instruct shop foreman
	34	Quality of repair service meets or exceeds commercial standards	Quality of PMs	Scheduled versus Unscheduled Repairs ratio equal or less than 80/20 ratio			Create "reason" codes in FMS to delineate PM from other repairs and instruct shops to use codes
	35	Quality of repair service meets or exceeds commercial standards	Mechanic Efficiency/Skill	90% or tested repairs completed within time standards.		Develop FMS report that details task code averages for in-house repairs by repair code and details mechanic's average performance vs. task code average. <b>Ongoing requirement for review at least annually.</b>	Select high volume task codes and develop target times based on industry manuals. Conduct review at least bi-annually.
	36	Quality of repair service meets or exceeds commercial standards	Shop efficiency, parts availability, and backlog.	80% of non-accident repairs completed within 24 hours; 80% of accident repairs completed within 3 days	Ensure work order date in and date out are captured in FMS	Create FMS report that reports total number of repairs, number and percent of non-accident completed in 1 day, and number and percent of accident repairs completed in 3 days. Target: 80%	



Fleet MT Category	Measure #	Proposed Critical Requirement	Proposed Review Process	Proposed Compliance Indicators	Year 1	Year 2	Year 3
	37	Shop meets safety and environmental requirements	Safety and environmental regulation check list exists, inspections are completed in accordance with schedule, results recorded, and actions documented	100% compliance with safety and environmental regulations	Create standardized safety and environmental check list and associated schedule.	Complete checks in accordance with schedule, record results and follow-up actions. <b>Ongoing requirement</b>	<b>Ongoing requirement</b>
	38	Customer satisfaction	Summary data from Customer Comment Cards is reviewed	95% rate maintenance service as adequate or above.		Create customer comment cards that include rating scale on service and provide to each customer after service is performed. Review comments weekly. Compile ratings monthly and total for year. Target: 95% rate service as adequate or above.	Determine percentage of cards completed and ensure rates are high enough for results to be representative. Review of comments and ratings is an <b>ongoing requirement</b> .
	39	Fuel inventory and use documented	Fuel purchase/inventory and fuel use records reconcile	Fuel inventory used reconciled with dispensing records monthly		Determine standard methodology and forms for completing fuel inventory reconciliation.	<b>Ongoing requirement</b>